



Providing sustainable energy solutions worldwide

Installation- and maintenance instruction
STG 146i/2 J/K IP40 Biogas

LMV37

DMW-DLE 512, FRS 510

RWF50.2



-sv

1. Manualer på övriga språk

2. [www.bentone.com\download](http://www.bentone.com/download) eller scanna QR-koden.

3. Skriv in brännarens artikelnummer som finns på din typskylt (se bild) och välj ditt språk.

Detaljerad ecodesign information kan laddas ner på:
www.bentone.com/ecodesign.

-fr

1. Manuels dans d'autres langues

2. [www.bentone.com\download](http://www.bentone.com/download) ou scannez le code QR.

3. Saisir le numéro d'article du brûleur sur votre plaque signalétique (consultez l'illustration) et sélectionnez la langue.

Des informations détaillées sur l'ecodesign peuvent être téléchargées à l'adresse:
www.bentone.com/ecodesign.



-en

1. Manuals in other languages

2. [www.bentone.com\download](http://www.bentone.com/download) or scan QR-code.

3. Enter the burner's article number on your data plate (see picture) and select language.

Detailed ecodesign information can be downloaded at:
www.bentone.com/ecodesign.

-de



1. Gebrauchsanweisungen in anderen Sprachen

2. [www.bentone.com\download](http://www.bentone.com/download) oder scannen Sie den QR-Code.

3. Geben Sie die Artikelnummer des Brenners auf Ihrem Typenschild ein, (siehe Bild) und wählen Sie die Sprache aus.

Detaillierte Informationen zum Ecodesign können unter www.bentone.com/ecodesign heruntergeladen werden.

3. exempel example Beispiel

352011030141	Serial no. 1234567	Man.Year 2019
Designation	BF 1 KS 76-24	
Type	BF 1	
Model	BF 1 KS 76-24	
Cap. Min-Max	LIGHT OIL 35-90KW 1,25-6,0 cSt 7-14bar	
Main supply	1-230V 1,0A 50Hz IP 20	
Motor supply		
MADE IN SWEDEN BY		

-da

1. Manualer på andre sprog

2. [www.bentone.com\download](http://www.bentone.com/download) eller scan QR-koden.

3. Indtast brænderens artikelnummer, der findes på typeskiltet (se billede), og vælg dit sprog.

Detaljerede oplysninger om ecodesign kan downloades på:
www.bentone.com/ecodesign.

Table of contents

1. General Information	4	6. Regulator RWF50	34
1.1 Delivery inspection	4	6.1 Connection of PT100 sensor	34
1.2 Safety	4	6.2 Operation	35
1.3 What to do if you smell gas	5	6.3 Basic display	36
2. Technical data	6	6.4 User level	37
2.1 Dimensions STG 146i/2	6	6.5 Starting the self-setting function	38
2.2 Capacity range	7	6.6 Parameterization PArA	39
2.3 Gas categories, approved gases	7	6.7 Configuration ConF	41
2.4 Electric Specification EN 60335-2-102	7	6.8 Analog input InP1	42
2.5 Working field	8	6.9 Controller Cntr	43
2.6 Setting for insert and air damper	8	6.10 Thermal shock protection (TSS) rAFC	44
2.7 Components	9	6.11 Control outputs OutP	45
3. Installation	11	6.12 Binary input binF	46
3.1 General instructions	11	6.13 Display diSP	47
3.2 Instructions	11	7. Automatic control unit LMV37	48
3.3 Inspection and maintenance	11	7.1 System structure/function description	48
3.4 Preparation for assembly	11	7.2 General information	49
3.5 Gas supply	11	7.3 Technical Data Basic unit LMV37.4...	49
3.6 Electric connection	11	7.4 Connection and internal diagram	54
3.7 Calculation of gas flow	12	8. Operation	56
3.8 Calculate prepurge time, Industrial applications	13	8.1 LMV37 automatic control unit	56
3.9 Mounting the burner to the boiler	14	8.2 List of phase displays	58
3.12 Gas nozzle	15	8.3 Automatic control unit levels	59
3.13 De-aerating	15	8.4 Setting the automatic control unit	64
3.10 Leakage control	15	8.5 Backup and restore	76
3.11 Electric function test	16	8.6 Fault status message, display of errors and info	80
4. Burner settings	17	8.7 Display message of info	86
4.1 Air settings	17	8.8 Resetting the automatic control unit	87
4.2 Brake plate adjustment	17	8.9 Manual output	88
4.3 Start-up	18	9. Parameter list	90
4.4 Adjustment	18	10. Error code list	99
4.5 Recommended excess air when using default setting	18	11. Electric equipment	112
4.6 Setting the air pressure switch	19	11.1 Safety system	112
4.7 Setting the gas pressure switch min.	20	11.2 Wiring diagram	113
4.8 Setting the gas pressure switch max/ overload protection switch	21	12. Handing over of the installation	115
4.9 Setting the gas pressure switch VPS	22	13. Troubleshooting	116
4.10 Double Solenoid valve Type DMV-D.../11 Type DMV-DLE.../11	23	14. Service- and inspection protocol	119
4.11 Gas pressure regulator Type FRS	25		
4.12 Skeleton diagram	27		
5. Burner service	28		
5.1 Combustion device	28		
5.2 Fan motor and fan wheel	29		
5.3 Air intake and intake cone	30		
5.4 Replacement of electrical components	31		
5.5 Vibration	31		
5.6 Flame detector QRC	32		
5.7 Burner Service Schedule, Gas	33		
5.8 Component replacement intervals	33		

1. General Information

The burner may only be used for its intended purpose in accordance with the product's technical data.

We reserve the right to make design changes and cannot be held liable for any misprints or typographical errors.

Modifying the design or using accessories or components that have not been approved by Enertech in writing is strictly prohibited.

This Installation and Maintenance manual:

- is to be regarded as part of the burner and must always be kept near the installation site.
- must be read prior to installation.
- is intended for use by authorised personnel.

1.1 Delivery inspection

- Make sure everything is delivered and the goods have not been damaged during transit. Transport damage should be reported to the shipping company.
- If something is wrong with a delivery, report it to the supplier.

1.2 Safety

- before installation:

- Installation and work on the burner and associated system components may only be carried out by persons who have undergone relevant training.
- The product is packaged to prevent damage from occurring when handled – Handle the product with care! Lifting equipment must be used to lift larger packages.
- The products must be transported/stored on a level surface in a dry environment, max. 80% relative humidity, no condensation. Temperature -20 to +60 °C.

- installation:

- The burner must be installed in accordance with local regulations for fire safety, electrical safety, and fuel distribution.
- The premises must comply with local regulations pertaining to use of the burner, and must have adequate air supply.
- The installation site must be free of chemicals.
- Fire extinguisher with Class BE recommended.
- Make sure when installing the burner that there is enough space to service the burner.
- The electrical installation must be professionally carried out in accordance with current high voltage regulations and in a professional manner.
- Make sure that the burner is suitable for the application (see Technical Data).



- All components must be installed without being bent, twisted or subjected to mechanical or thermal forces that affect components.
- Care must be taken by the installer to ensure that no electrical cables or fuel lines are crushed or otherwise damaged during installation or service.
- Sharp edges can occur on, for example: flame tube, fan wheel and air damper.
- The gas outlet from the pressure regulator must be configured in accordance with applicable regulations and lead to a safe area.

- before first start:

- The burner must not be put into operation without proper safety and protection devices.
- Permitted ambient temperature during operation -10 to +60 °C. Max. 80% relative humidity, no condensation.
- The surface temperature of the burner's components may exceed 60 °C.
- Handle with caution – the burner has moving parts, and there is risk of crushing injuries.
- Seal inspections must be performed during installation and servicing to prevent leakage.
- Fitting and installation work has been completed and approved.
- Electrical installation has been correctly performed.
- Flue gas ducts and combustion air ducts are not blocked.
- All actuators and control and safety devices are in working order and correctly set.
- If the boiler is equipped with an access hatch, this must be equipped with a hatch opening switch connected to the burner's safety system.
- When in operation, the burner's noise level can exceed 85 dBA – use hearing protection!

- Operation:

- Carry out all stipulated settings, service and inspection work within the set time.

1.3 What to do if you smell gas

- Turn off the fuel supply.
- Turn off the equipment and remove the boiler from operation.
- Open windows and doors.
- Prevent open flames or sparking, e.g. do not turn lights on or off, do not use any electrical appliances or mobile phones.
- Evacuate the building.
- Notify the installer or gas supplier of the problem so that it can be rectified.



2. Technical data

The burner is intended for:

- Operation with boiler according to EN 303 and EN 676.

Fuels:

- Natural gas H, E, L, LL.
- Dry biogas max 0.1 Vol% H₂S and min 50% CH₄.

2.1 Dimensions STG 146i/2

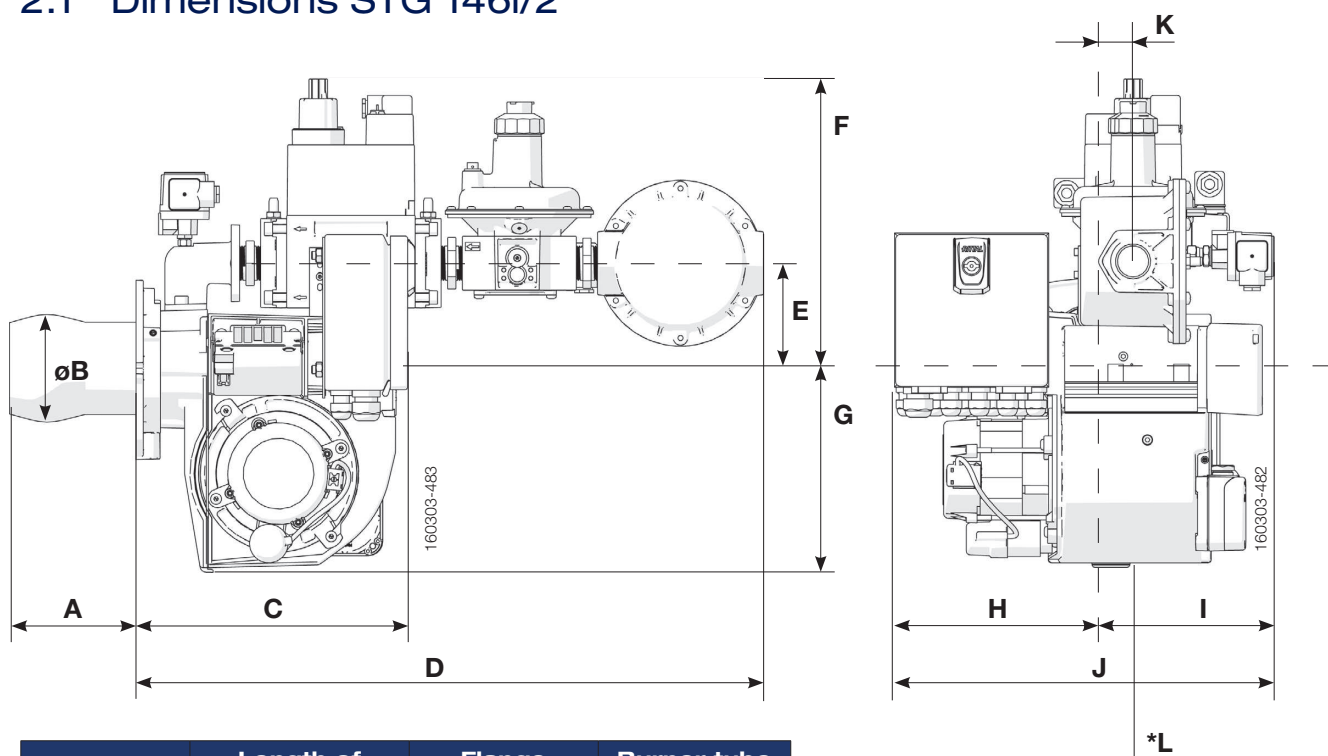

Type	Length of burner tube	Flange measure A	Burner tube measure B
STG 146i/2	145	122	ø104
	245	222	ø104

	C	D	E	F	G	H	I	J	K	*L
STG 146i/2	262	605	101	279	197	200	169	369	32	200

* Min. recommended distance to floor.

2.1.1 Measurements for connection to boiler

	M	N	O	P
STG 146i/2	M10	Ø 110	Ø 140-170	12.5

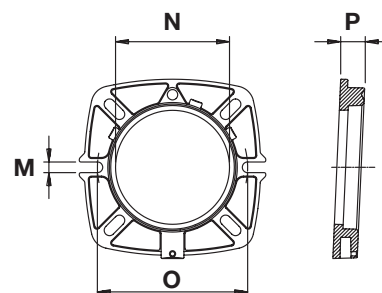

172 535 14

2.2 Capacity range

Capacity kW	Gas quantity at min. power Nm ³ /h	Gas quantity at max. power Nm ³ /h	Max. connection pressure mbar	Min. connection pressure mbar	Gas valve MultiBloc
STG 146/2					
G20 - 41-133	4.1	13.3	360	20	DMV-DLE 512 FRS 510
G25 - 41-133	5.1	16.7	360	20	DMV-DLE 512 FRS 510
Biogas			360	20	DMV-DLE 512 FRS 510

160303-496

Gas quantity and capacity vary according to grade of gas and connection pressure.

2.3 Gas categories, approved gases

Components are approved for dry biogas with a maximum content of 0.1% H₂S.

Category	Country of destination	Supply pressure
I _{2R}	AT, BE, BG, CH, CY, CZ, DE, DK, EE, ES, FI, FR, GB, GR, HR, HU, IE, IS, IT, LT, LU, LV, MK, MT, NL, NO, PL, PT, RO, RS, SE, SI, SK, TR	20 mbar
I _{2ELL}	DE	20 mbar
I _{2H}	AT, BG, CH, CZ, DK, EE, ES, FI, GB, GR, HU, IE, IS, IT, LT, LV, NO, PT, RO, SE, SI, SK, TR	20 mbar
I _{2Er}	FR	20 mbar
I _{2E}	LU, PL	20 mbar
I _{2E(R)B}	BE	20 mbar
I _{2L}	NL	20 mbar

160303-218-2

2.4 Electric Specification EN 60335-2-102

Type	STG 146i/2
Electrical data, Control power	230V, 1~, 1.6A, 50Hz, IP40
Electrical data, Motor	-
Max fuse rating	10A
Noise level	79dBA

Max operating current, see data plate.

Measurements according to EN 3746: 2010

Alt.1 The sound level of the burner can be reduced by equipping the burner with silencer. Installation must be done so it does not prevent air supply to the burner.

Alt.2 The burner's noise level can be reduced by connecting the burner's air intake to the air duct that opens into an appropriate location. Installation must be done so it does not prevent air supply to the burner.

2.5 Working field

41-110 kW

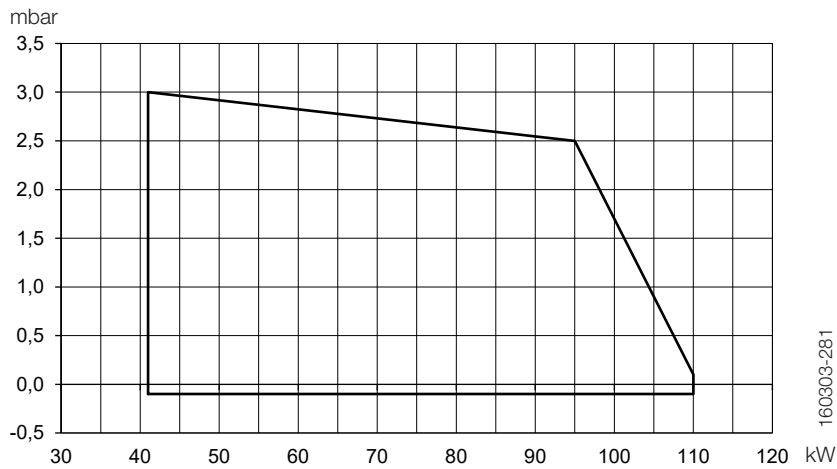

! Do not exceed working field.

160303-281

2.6 Setting for insert and air damper

Basic settings should only be seen as setting values to get burner to start. Once the burner has started and established flame, it is necessary to adjust the settings so that they are adapted to the installation and the fuel used.

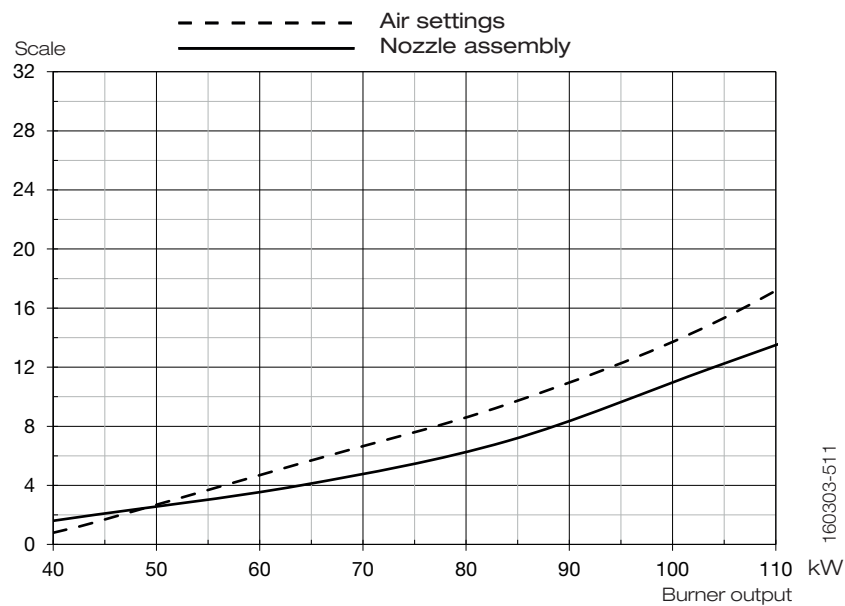

160303-511

2.7 Components

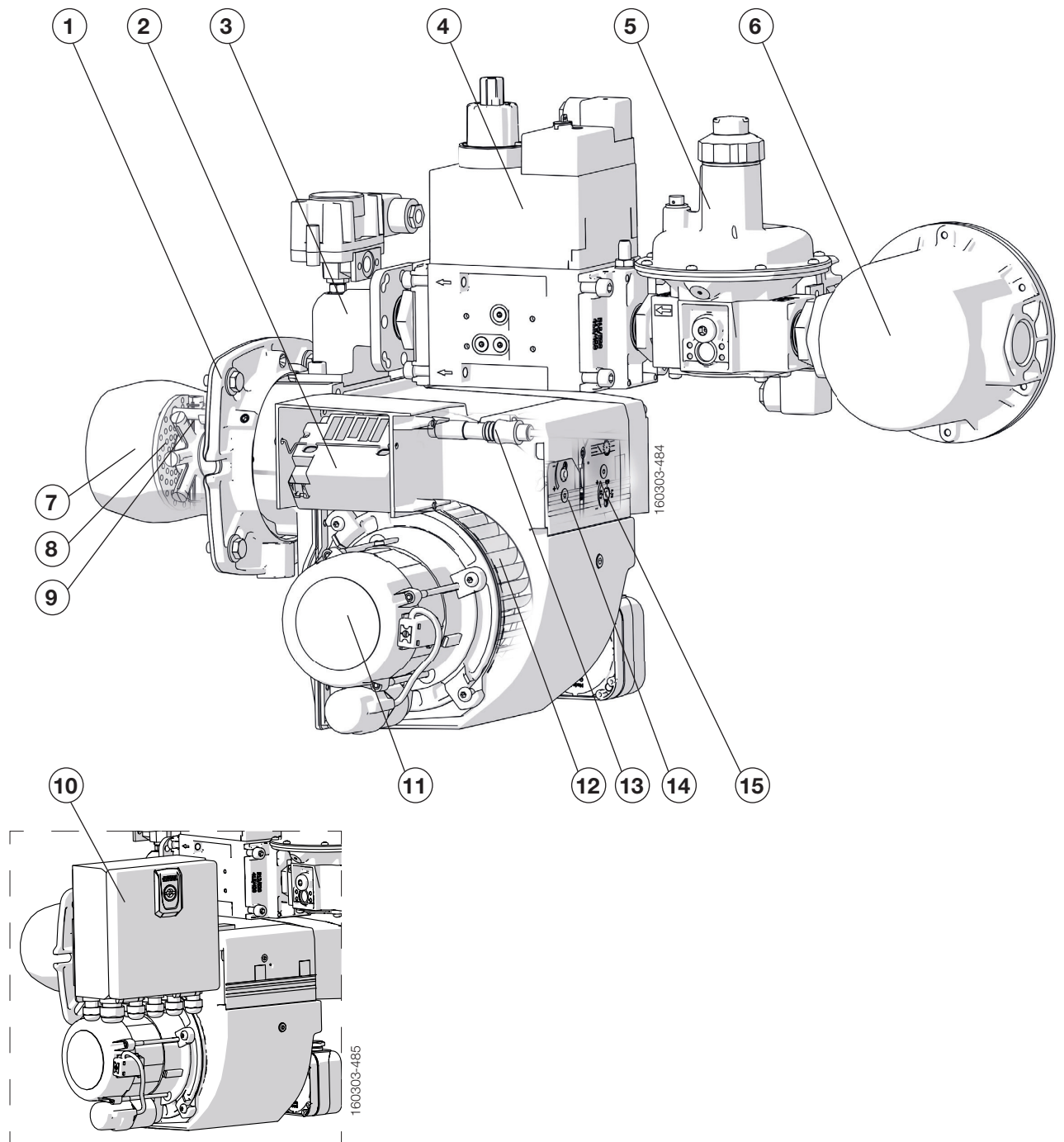

- | | | |
|-------------------------|-----------------------|----------------------------|
| 1. Connecting flange | 6. Filter | 11. Motor |
| 2. Transformer | 7. Flame tube | 12. Fan wheel |
| 3. Connection Gas valve | 8. Brake plate | 13. Flame detector |
| 4. Gas valve | 9. Ignition electrode | 14. Brake plate adjustment |
| 5. Pressure regulator | 10. Electrical box | 15. Air setting |

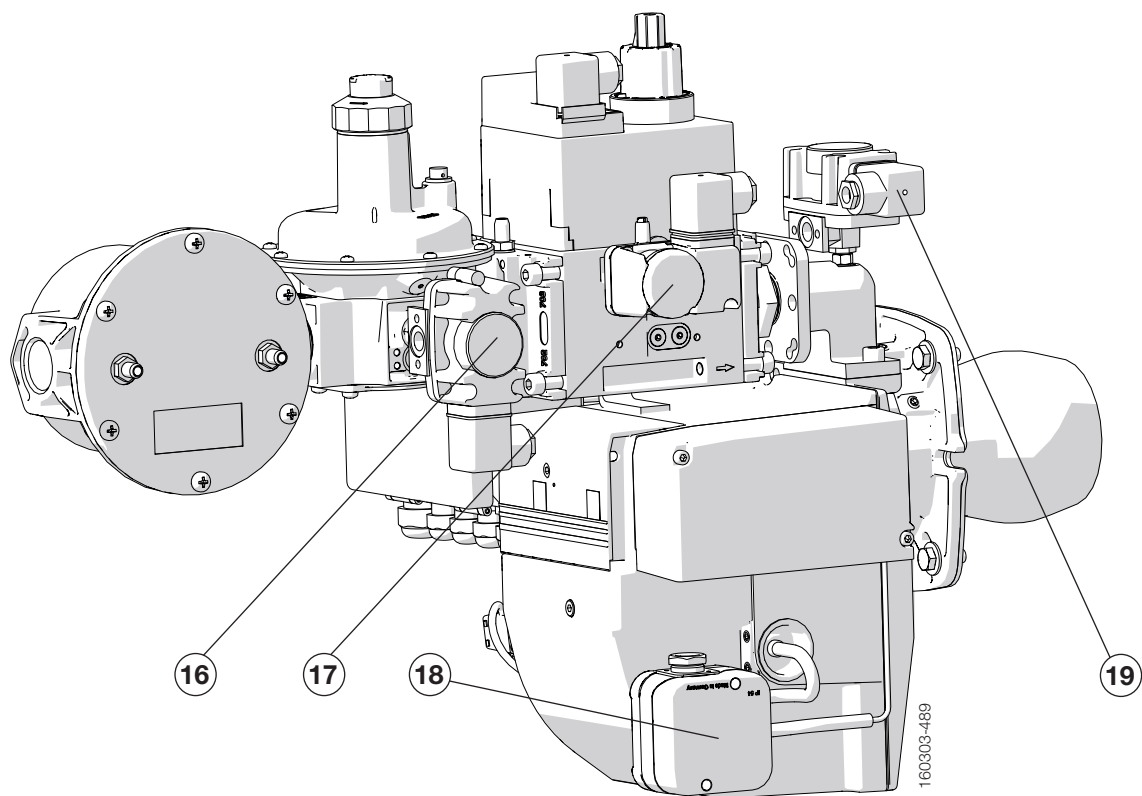

- | | |
|------------------------------|---|
| 16. Gas pressure switch min. | 19. Gas pressure switch max./
Overload protection switch |
| 17. Gas pressure switch VPS | |
| 18. Air pressure switch | |

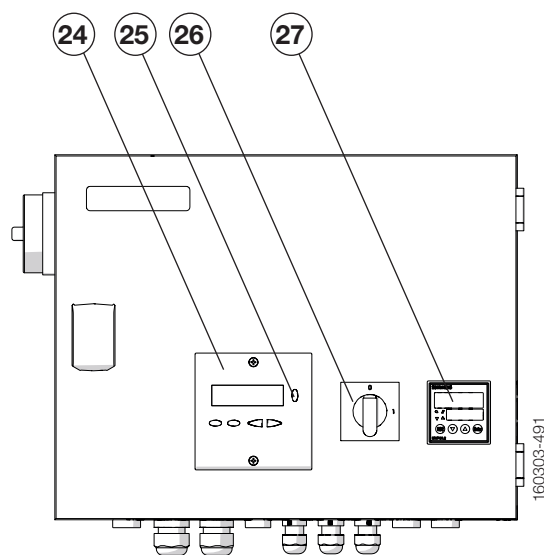
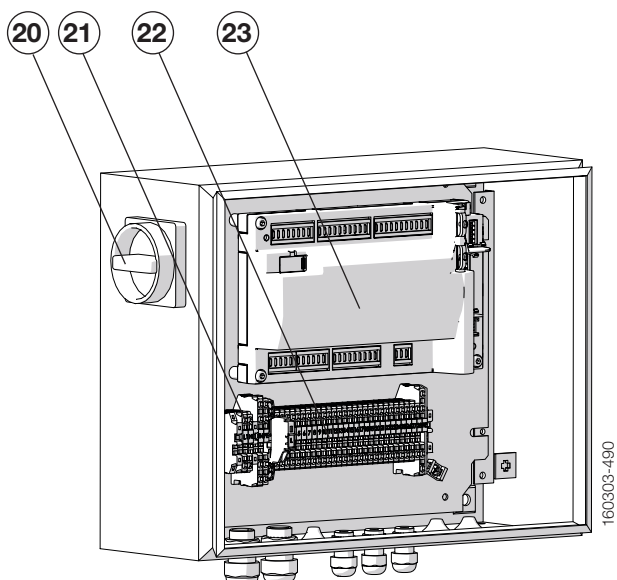

2.7.1 Components, electrical cabinet

- | | | |
|----------------------|--------------------------------|--------------------------|
| 20. Main switch | 23. Automatic control unit LMV | 25. Reset |
| 21. Fuse | 24. Display AZL | 26. Operating switch 0-I |
| 22. Connection block | (automatic control unit) | 27. Regulator RWF |

3. Installation

3.1 General instructions

Installation must be carried out in accordance with current regulations and instructions.

The supplier/installer of the facility is obliged to familiarize himself with all regulations so that the installation meets the requirements of the local authorities.

Installation, assembly and adjustment must be performed to obtain the best possible function. Only gas intended for the gas burner may be used.

3.2 Instructions

It is the installer's responsibility to instruct the user in detail in the functions of the gas burner and the entire plant.

3.3 Inspection and maintenance

The system must be maintained at the interval specified in the service schedule. If the burner is in a dirty environment, service should be done at more frequent intervals.

3.4 Preparation for assembly

Check that the burner's dimensions and capacity range match the current boiler. The power information on the type plate refers to the burner model's min. and max. effect.

3.5 Gas supply

In order to obtain good operational safety, it is important that the installation of the gas distribution system is carried out correctly, considering the following:

- Check that the burner is approved for the gas quality of the installation.
- Check that the burner gas components are approved for the specified gas pressure, see type plate.
- Installation must be carried out in accordance with current standards.
- Pipe lines should be assembled so that service can easily be performed on the boiler and burner.
- Pipe lines should be assembled so that any contaminants do not come into contact with the gas components.

3.6 Electric connection

- Before work on the electrical connection, the current must be disconnected so that the installation is isolated.
- Connection must be done in accordance with the applicable regulations.
- Connection must conform to the wiring diagram.



If any electrical connection other than that recommended by Enertech is used, there is a risk of property damage and personal injury.

172 535 09

3.7 Calculation of gas flow

Formula symbol	Description	Example values
V_N	Standard gas volume [Nm ³ /h] Gas volume at normal condition 15 °C 1013 mbar	-
Q	Boiler output [kW]	80 kW
H_i	Lower calorific value of gas [kWh/m ³] Natural gas under normal conditions 15 °C 1013 mbar, EN 676	9.45 kWh/m ³
η	Boiler efficiency (e. g. 90%)	0.9
f	Conversion factor (pressure and temperature compensation)	-
t_{Gas}	Gas temperature at gas meter [°C]	15 °C
P_{Baro}	Barometric air pressure [mbar]	945 mbar
P_{Gas}	Pressure of gas at the gas meter [mbar]	20 mbar
V	Operating volume [m ³ /h]	-
V_G	Gas flow measured at the gas meter [m ³]	0.26 m ³
T	Measuring time for consumed gas quantity [s]	90 s

Calculate standard volume using the following formula:

$$V_N = \frac{Q}{\eta \cdot H_i} \quad V_N = \frac{80 \text{ kW}}{0.9 \cdot 9.45 \text{ kWh/m}^3} = 9.4 \text{ m}^3/\text{h}$$

Calculate conversion factor using the following formula:

$$f = \frac{273}{273 + t_{Gas}} \times \frac{P_{Baro} + P_{Gas}}{1013} \quad f = \frac{273}{273 + 15} \cdot \frac{945 + 20}{1013} = 0.90$$

Calculate gas volume using the following formula:

$$V = \frac{V_N}{f} \quad V = \frac{9.4 \text{ m}^3/\text{h}}{0.90} = 10.4 \text{ m}^3/\text{h}$$

Determine operating volume with the following formula:

$$V = \frac{3600 \cdot V_G}{T} \quad V = \frac{3600 \cdot 0.26 \text{ m}^3}{90 \text{ sek}} = 10.4 \text{ m}^3/\text{h}$$

Height above sea level [m]	0	100	200	300	400	500	600	700	800	900	1000	1100	1200
P_{Baro} [mbar]	1013	1001	989	977	966	954	943	932	921	910	899	888	877

Calorific value of the gas

Gas quality		kWh/Nm ³	MJ/Nm ³
Natural gas	G20	9.5	34.02
Natural gas	G25	8.2	29.25

Lower calorific value H_i at normal conditions 15 °C and 1013 mbar, EN 676.

For exact calorific value of the gas, contact the gas distributor.

3.8 Calculate prepurge time, Industrial applications

Prepurge time can be set on control unit LMV with parameter 225.

Formula symbol	Description	Example values
V	Volume fire box [m ³]	2 m ³
Q	Burner output [kW]	200 kW
T	Prepurge time [s] Industrial applications according to EN 746. The prepurge time must correspond to at least 5 complete air circulations in the fire box and adapted compartments.	

Calculate prepurge time using the following formula:

$$T = \frac{V \cdot 5}{Q \cdot 1.2 / 3600} \quad T = \frac{2 \text{ m}^3 \cdot 5}{200 \text{ kW} \cdot 1.2 / 3600} = 150 \text{ s}$$

3.9 Mounting the burner to the boiler

The burner is mounted on the boiler with bolts (A) according to the hole pattern on the connection flange.

1. Install the connection flange (B) and the enclosed gasket (C) on the boiler. If new mounting holes need to be drilled, use the connection flange as a template and fasten with M8-M10 screws.
2. Loosen the burner tube (D) and fit the enclosed gasket (E) around the flame tube and check that the ignition electrodes are set correctly, see chapter Gas nozzle.
3. Mount the burner on the connection flange and fasten with screws (F).
4. Check/Mount the enclosed o-ring on the gas connection and mount the gas fixture on the burner.
5. Connect electrical connection for gas valve, gas pressure switch min, gas pressure switch max and VPS/Tightness check.
6. Connect gas line, connect supply cable, operating and safety circuits.

! Before obtaining access to terminals, all supply circuits must be disconnected.

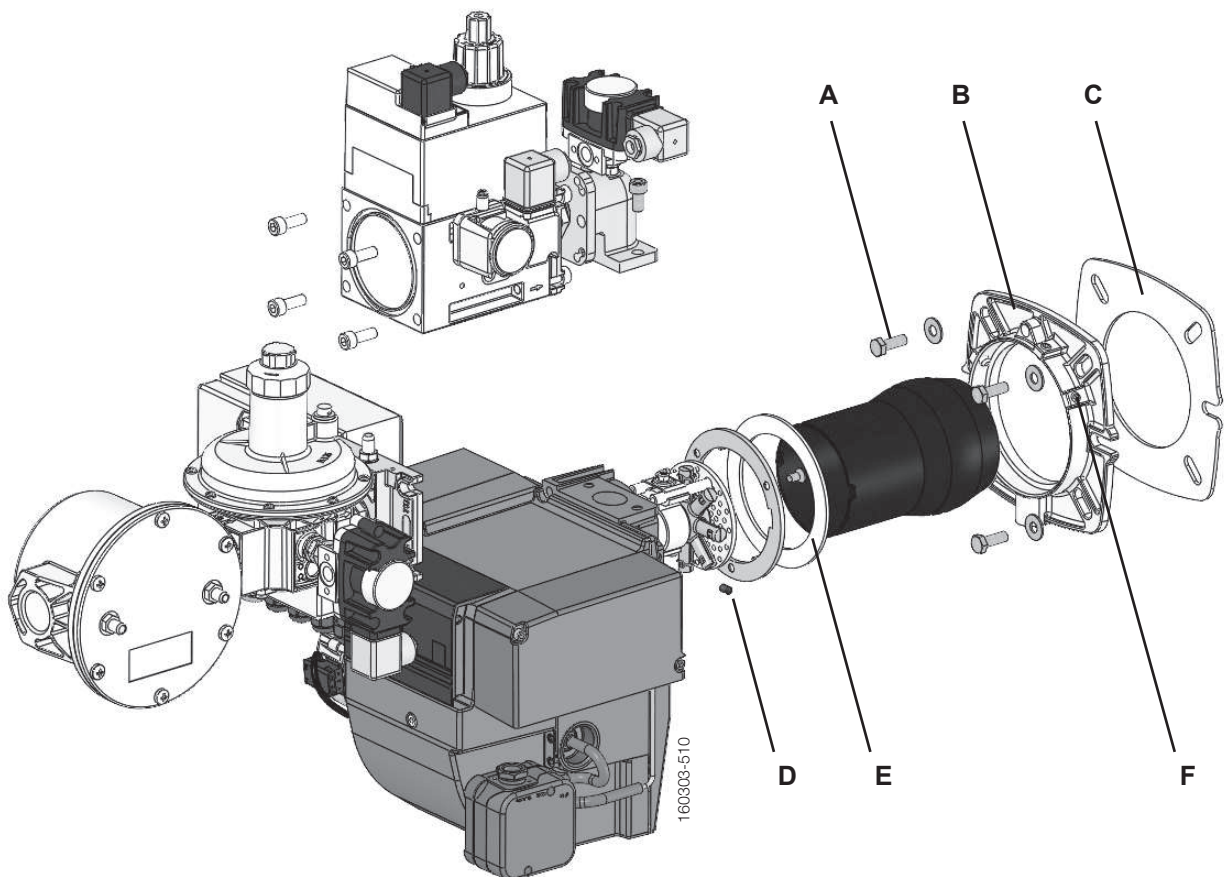

3.12 Gas nozzle

Check that the ignition electrodes are set correctly before assembly on the boiler.

Biogas

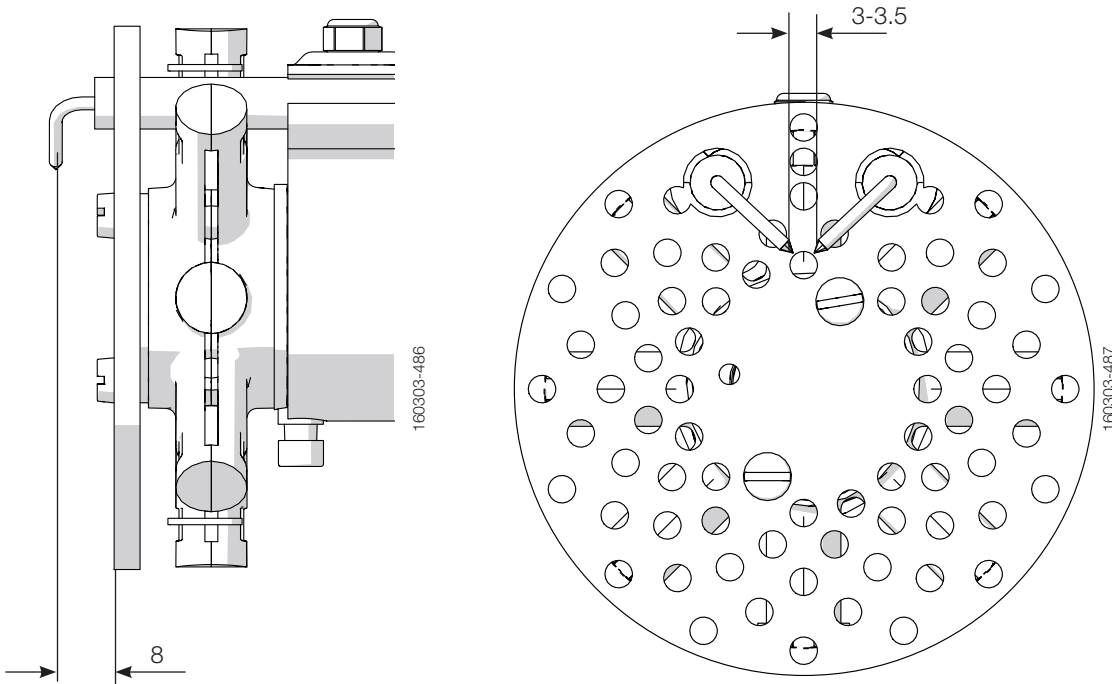

3.13 De-aerating

De-aerating the gas line by closing the tap for the gas connection and unscrewing the screw on the measuring nipple for the connection pressure. Connect a plastic hose, open the tap and discharge the gas to a safe place. When de-aerating is complete, do not forget to screw the screw back into the measuring nipple.

3.10 Leakage control

When testing for leaks, the solenoid valve must be closed. Connect a pressure gauge to the test nipple "Pa", see figure. The test pressure in the system must not be higher than max. connection pressure, see type plate. If leaks are found during measurement, locate the leaky spot using soapy water or leak detection spray. After sealing, the system is tested for leaks again.

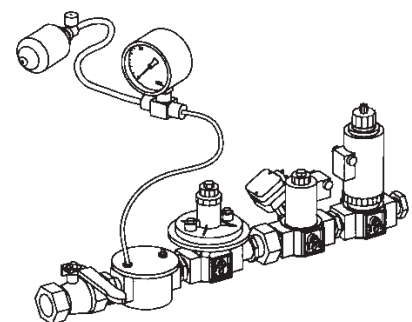
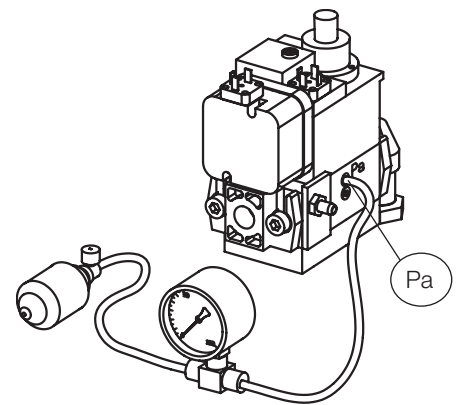

! Check the gas tightness.

3.11 Electric function test

When connecting from the mains, make sure that phase and neutral are not reversed. The gas tap must be closed. Temporarily link the gas pressure switch so that it does not block.

The prepurging time (30-35 sec.) begins after switching on the main switch and setting the maximum and control thermostats. After this time, the preignition comes into operation (0.5-2.5 sec. depending on the design of the gas burner control).

The ignition spark must be able to operate flawlessly at the amount of air required for combustion. The gas valve is energized and opens. After the end of the safety period (2-3 sec.), the gas burner control goes into blockage. Solenoid valve and motor become de-energized. Remove the link after testing.

4. Burner settings

4.1 Air settings

Prior to commissioning, adjust the burner air damper setting according to the diagram Basic setting, see Technical data. After the first start, the burner must be adjusted again for good function and combustion.

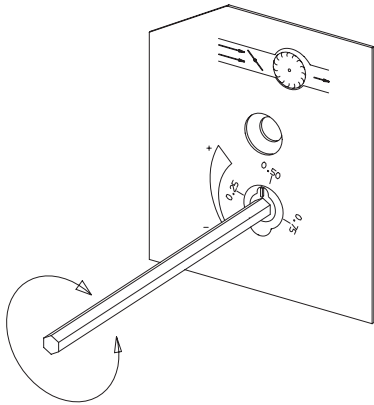

4.2 Brake plate adjustment

The burner is equipped with a brake plate adjustment that changes the position of the brake plate in the burner head. The position of the brake plate must be adjusted to achieve as favorable a pressure drop across the brake plate as possible.

Which position to use depends on gas flow and overpressure in the boiler. At lower capacities, however, the opening should be smaller between the brake plate and the combustion device. Turn the screw in the desired direction with an Allen key.

- Turn screw to the right to reduce opening.
- Turn screw to the left to increase opening.

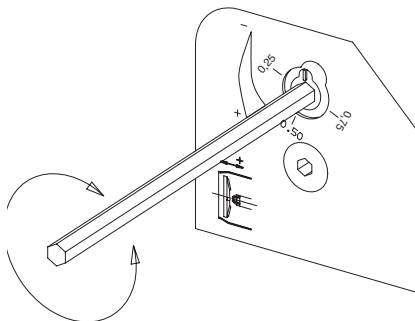

4.3 Start-up

After the burner has been fitted to the boiler, the electrical connection is complete, the gas piping is seal tested and de-aerated, and the electrical function test has been carried out, the burner is ready for start-up.

Read the sections on setting of the gas valve, damper motor and combustion device before starting.

Open the ball valve and switch on the main switch, start the burner and start adjusting the system.

4.4 Adjustment

Check the combustion using flue gas analysis instruments. Set the burner to about 20% excess air and check the flue gas temperature. Calculate the combustion efficiency. Also check the current amount of gas on the gas meter so that the correct applied power is achieved.

4.5 Recommended excess air when using default setting

Gas quality	Excess air flue gases		Max % CO ₂
	% O ₂	% CO ₂ Lambda 1.2	
Natural gas	3 - 5	≈10	11.9
Propane	3 - 5	≈11.5	13.9
Butane	3 - 5	≈11.5	14.1
Liquefied petroleum gas	3 - 5	≈11	13.8
Biogas	3 - 5		

4.6 Setting the air pressure switch

The air pressure switch must block the burner if the amount of air for combustion becomes too low. The air pressure switch must be set so that in the event of a lack of air supply at the burner's max. or min. capacity reacts before the monitored pressure drops so much that poor combustion occurs.

1. Remove protective cover, screws (Y).



Be careful when adjusting the air pressure switch; it contains a live component.

2. Start the burner.
3. Carefully turn the scale on the air pressure switch clockwise until the air pressure switch stops the burner.
4. Measure and note the lowest air pressure in the entire work area.
5. Set the air pressure switch to about 10-15% lower than the lowest noted pressure.
6. Test run the burner and check the function in the entire work area.
7. Refit protective cover, screws (Y).



4.7 Setting the gas pressure switch min.

The gas pressure switch must react to too low a connection pressure to the burner, prevent the burner from starting and stop the burner during operation. The burner may start again when the connection pressure has risen above the set pressure on the gas pressure switch.

1. Remove protective cover, screws (Y).
2. Open measuring socket (X) and connect a manometer for measuring connection pressure.
3. Start the burner.
4. Measure and note the connection pressure to the burner at the highest input power.
5. Set the gas pressure switch to a value 10-15% lower than the noted pressure.
6. Check the setting by carefully closing the ball valve and at the same time measuring the connection pressure.
7. When the gas pressure switch stops the burner, the measured value must approximately correspond to the setting on the gas pressure switch.
8. Open ball valve.
9. Remove manometer and close measuring socket (X).
10. Refit protective cover, screws (Y).



Check gas tightness.



4.8 Setting the gas pressure switch max/ overload protection switch

The gas pressure switch must react to excessive gas pressure in the burner. Start can only be done by manual reset (gas burner control or overpressure switch).

The switch blocks the burner if gas pressure between gas valve and burner becomes too high. The overload protection switch can be connected so that it provides automatic restart or that the burner is blocked, see S10 or S16 in the wiring diagram. The system's safety regulations control connection options.

1. Remove protective cover, screws (Y).
2. Open measuring socket (X) and connect a manometer for measuring connection pressure.
3. Start the burner.
4. Measure and note the highest gas pressure in the entire work area.
5. Set the gas pressure switch to a value 10-15% lower than the noted pressure.
6. Test run the burner and check the function in the entire work area.
7. Remove manometer and close measuring socket (X).
8. Refit protective cover, screws (Y).



Check the gas tightness.

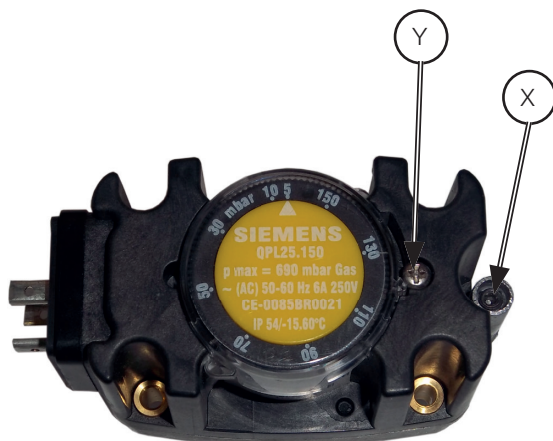

4.9 Setting the gas pressure switch VPS

Gas pressure switch VPS is used to detect leaky gas valves.

1. Remove protective cover, screws (Y).
2. Open measuring socket (X) and connect a manometer for measuring connection pressure.
3. Start the burner.
4. Measure and note lowest and highest gas pressure during start-up.
5. Set the switch to a value between these values.
6. Test run the burner and check the function in the entire work area.
7. Remove manometer and close measuring socket (X).
8. Refit protective cover, screws (Y).



Check the gas tightness.

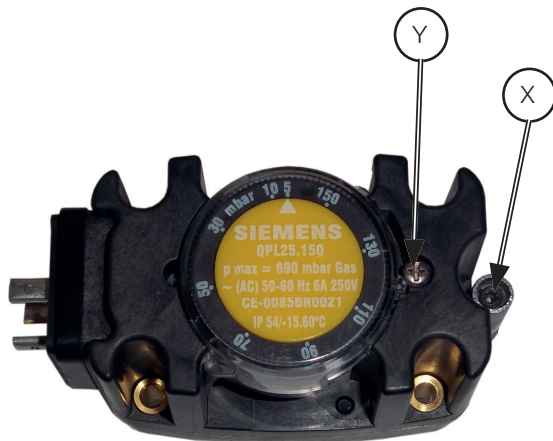

4.10 Double Solenoid valve Type DMV-D.../11 Type DMV-DLE.../11

Nominal widths

Rp 1/2 - Rp 2

Electrical connection IEC 730-1
(VDE 0631 T1)

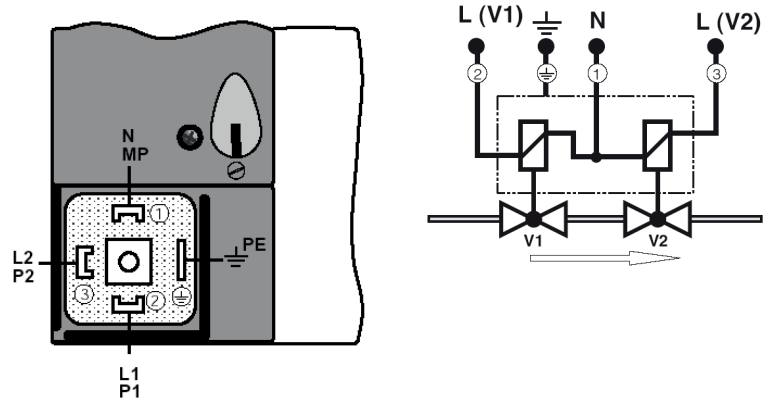

Volt	U _n ~ (AC) 230 V
Valve	2 x Class A
Ambient temperature	-15 °C ... +60 °C
IP	54
Family	1 + 2 + 3
Max. operating pressure	500 mbar

DMV 505-520/11

Pressure taps 1, 2, 3, 4 Sealing plug

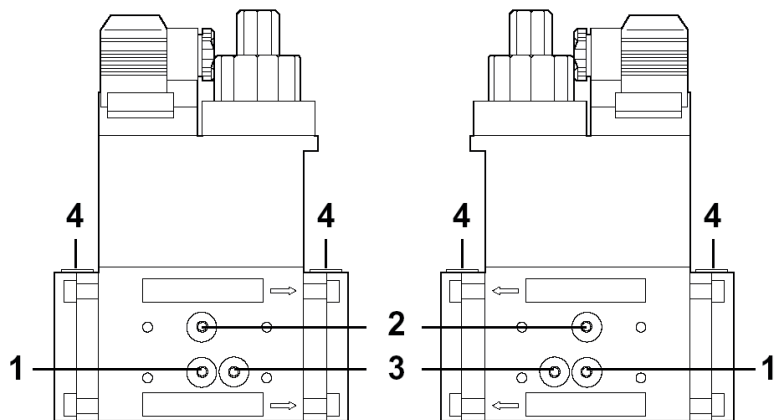

Screw plugs 1,2,3 may also be replaced by a measuring socket

G 1/8 DIN ISO 228.

Concealed connecting bore for system accessories.

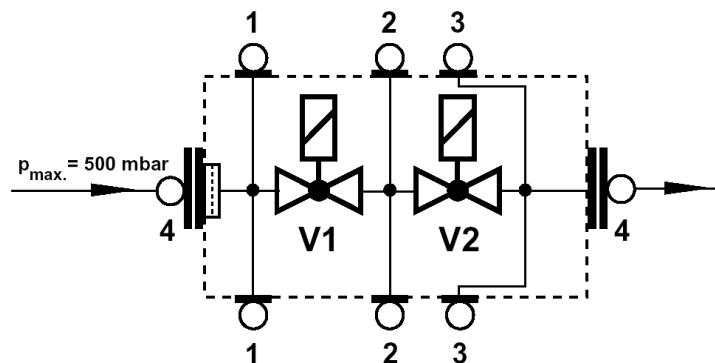

6.

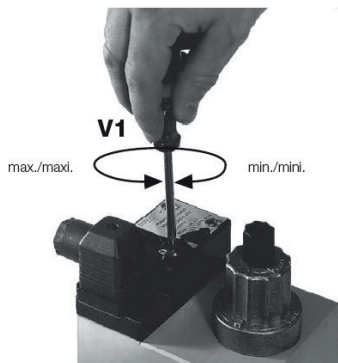

6. DMV - D 507/11 - 525/11 DMV-DLE 507/11 - 525/11 Main flow setting only possible at V1! Set main volume on open valve. Set valve V1 during operation. Check setting values continuously. Smallest setting volume flow:

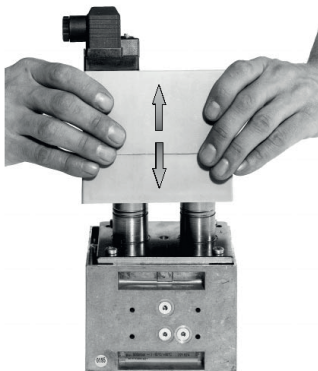

9. Replacing the solenoid Versions with adjusting plate DMV-D 5.../11 or hydraulic brake DMV-DLE 5.../11

1. Remove hydraulic brake or adjusting plate as described on page 6: "Replacing the hydraulic brake or adjusting disk", steps 1 - 5.
2. Replace solenoid
Important: Make sure that the solenoid no. and voltage are correct!
3. Remount hydraulic brake or adjusting plate as described on page 6. "Replacing the hydraulic brake or adjusting plate", steps 7 - 11.

7.

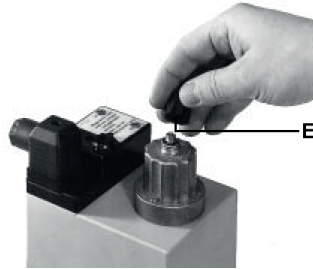

7. DMV-DLE Rapid stroke adjustment V start Factory setting DMV-DLE: Rapid stroke not adjusted

1. Unscrew the adjustment cap E from the hydraulic brake.
2. Turn the adjustment cap and use as a tool.
3. Turn a-clockwise = increase rapid stroke (+).

8.

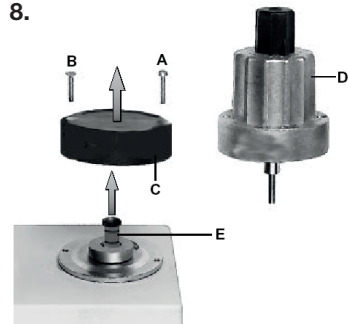

8. Replacing hydraulic brake unit or adjustment plate

1. Switch off firing system.
2. Remove locking varnish from countersunk screw A.
3. Unscrew countersunk screw A.
4. Unscrew socket headscrew B.
5. Raise adjustment plate C or hydraulic brake D.
6. Remove sealing plug E
7. Exchange adjustment plate C or hydraulic brake D
8. Screw in countersunk and socket head screw. Only tighten socket head screw so that hydraulic brake can just be turned.
9. Coat countersunk screw A with locking varnish.
10. Leakage test: Pressure tap at sealing plug 2:
DMV 507-520/11 Pressure tap 2 sealing plug 3: DMV 525/11 p max. = 500 mbar.
11. Perform functional test.
12. Switch on firing system.

4.11 Gas pressure regulator Type FRS

Nominal diameters

Rp 3/8 - Rp 2 1/2

DN 40 - DN 150



Never close vent nozzle!

Pressure taps

1. Vent plug
2. Connection for external pulse
G 1/4 screw plug ISO 228, on
both sides, optional.
3. G 1/4 screw plug ISO 228, in
inlet pressure range, on both
sides

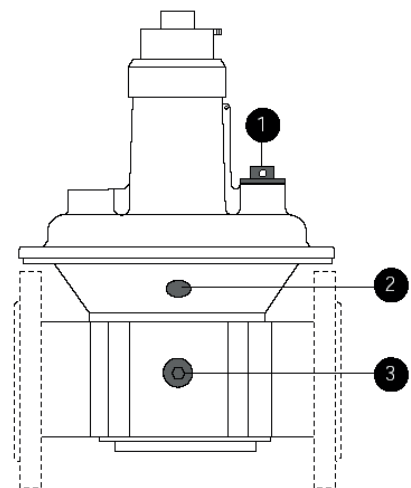
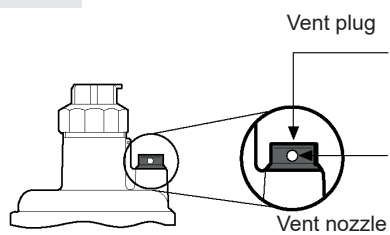

Max. operating pressure	500 mbar
Pressure regulator	Class A
Ambient temperature	-15 °C ... +70 °C
Inlet pressure range	5 - 500 mbar
Family	1 + 2 + 3
Outlet pressure range	2,5 - 200 mbar

Adjustment of outlet pressure
(setpoint adjustment)

Factory setting: Standard spring p 2
10-30 mbar

1.

1. Unscrew protective cap A.
2. Adjustment (+) Setting spindle B "Turn counter-clockwise" = Increasing outlet pressure (setpoint)

or

2.

- Adjustment (-) Setting spindle B "Turn clockwise" = Reducing outlet pressure (setpoint)

4. Check setpoint

5. Screw on protective cap A.

6. Attach lead seal (Page 5).

1.

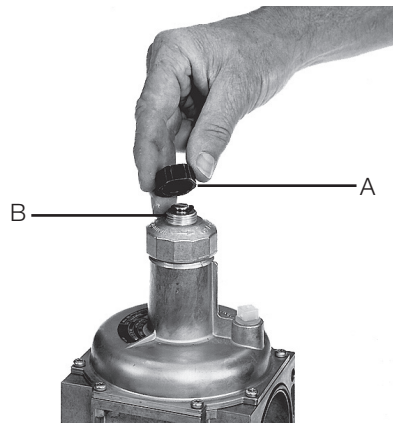

2.

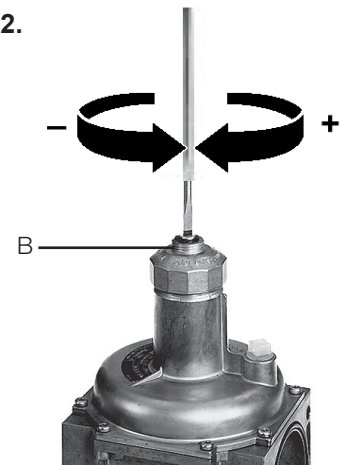

Replace setting spring 3-4

1. Remove protective cap A. Release spring by turning adjustment spindle B counter clockwise. Turn spindle to stop.
2. Unscrew complete adjustment device B and remove spring C.
3. Insert new spring D.
4. Assemble complete adjustment device and adjust desired off-set.
5. Screw on protective cap A. Stick adhesive label E onto typeplate.
6. Attach lead seal.

3.

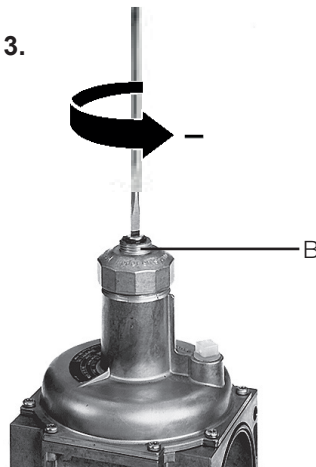

4.

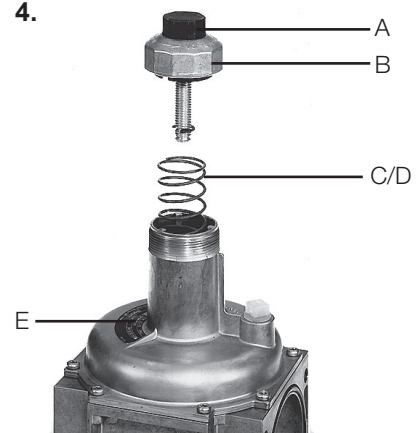

4.12 Skeleton diagram

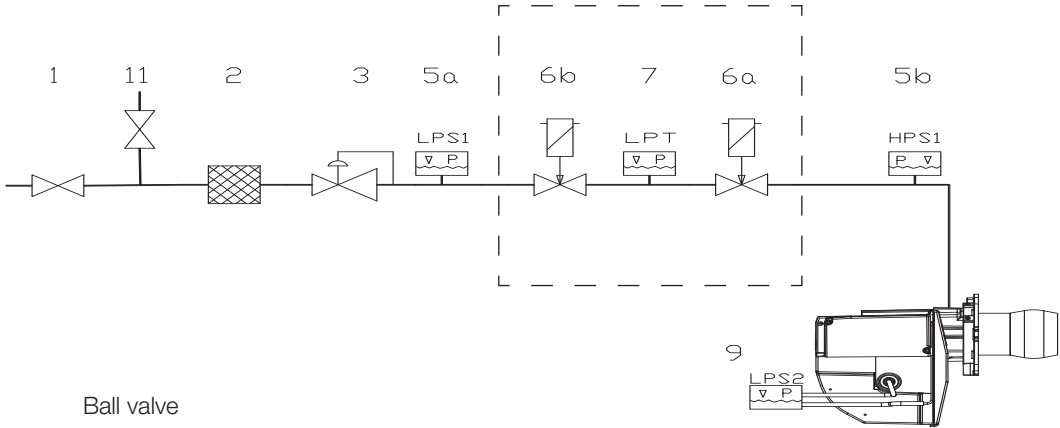

- 1 Ball valve
- 2 Filter
- 3 Pressure regulator
- 5a Gas pressure switch, min
- 5b Gas pressure switch, max
- 6a/b Double solenoid valve
- 7 Valve proving system
- 9 Air pressure switch
- 11 Ventilation pipe for releasing gas

5. Burner service

Service and maintenance work may only be performed by qualified personnel. Functional control of all safety systems and components. Only Enertech original parts should be used when replacing components.



Use caution when operating the burner, surfaces may be hot.



5.1 Combustion device

1. Switch off the main power supply and turn off the gas.



Before obtaining access to terminals, all supply circuits must be disconnected.

2. Remove gas line by loosening the electrical cabling and screws (G) to the gas valve and lift out.
3. Loosen screws (H) and lift burner out of connection flange.
4. Loosen screws (I) and remove flame tube.
5. Clean brake plate and nozzle if necessary.
6. Check electrodes, replace if necessary! (See chapter "Gas nozzle" for setting electrodes).
7. Mount the flame tube and attach the burner to the connection flange.
8. Install gas line and check for leaks.
9. Turn on the main power and open the gas flow.
10. Start burner and check/adjust combustion.

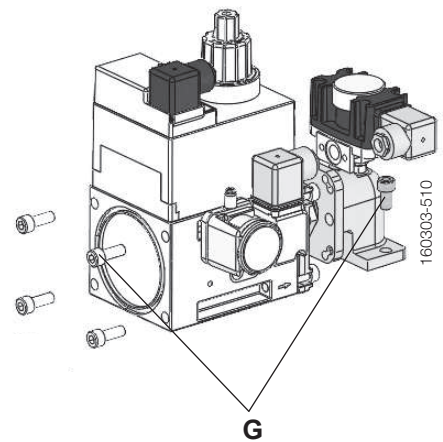

Check gas tightness.

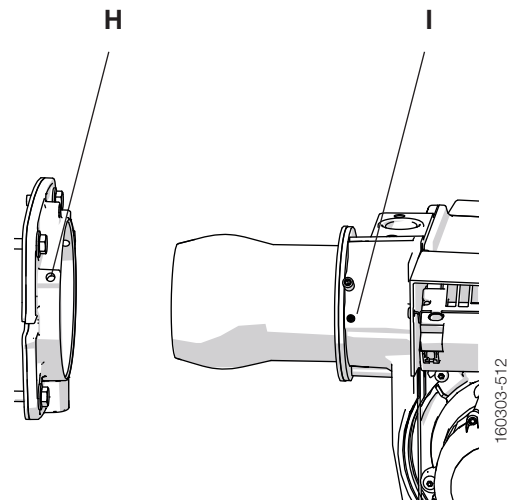

When servicing/replacing components that affect combustion, flue gas analysis and soot test shall be carried out on the installation.

172 615 90

5.2 Fan motor and fan wheel

1. Switch off the main power supply and turn off the gas.

! Before obtaining access to terminals, all supply circuits must be disconnected.

2. Disconnect electrical connection to the motor.
3. Loosen screws on the motor flange and lift out the motor.
4. Loosen and remove the fan wheel, clean or replace if necessary.
5. If replacing the motor, mount on the existing motor flange.
6. Check that the o-ring (J) is intact and that it is not damaged during mounting.
7. Fit the fan wheel so that there is a small gap between the motor and the fan wheel, check that no scratch noise are heard or any imbalance.
8. Refit the motor.
9. Connect the motor's electrical connection.
10. Turn on the main power and open the gas flow.
11. Start burner and check/adjust combustion.

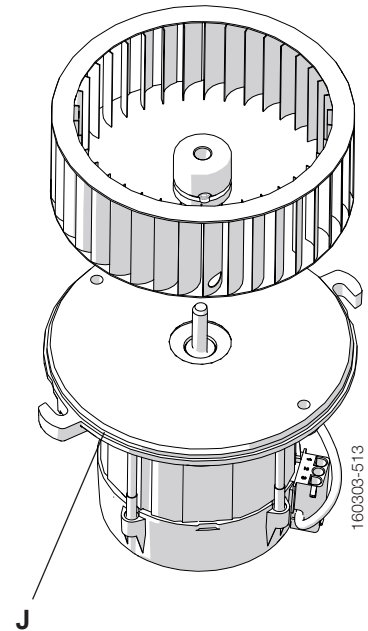

! When servicing/replacing components that affect combustion, flue gas analysis and soot test shall be carried out on the installation.

5.3 Air intake and intake cone

1. Switch off the main power supply and turn off the gas.



Before obtaining access to terminals, all supply circuits must be disconnected.

2. Remove gas line by loosening the electrical cabling and screws to the gas valve and lift out.
3. Loosen screws and lift burner out of connection flange.
4. Remove air intake and flame tube.
5. Disconnect ignition cable.
6. Disassemble the burner by loosening the through screw (K) and removing the front piece.
7. Check function and appearance of the various components included in the air control. Clean and replace components if necessary.
8. Mount the burner in reverse order. Be sure to mount components in the same position as when disassembling.
9. Turn on the main power and open the gas flow.
10. Start burner and check/adjust combustion.



Check gas tightness.

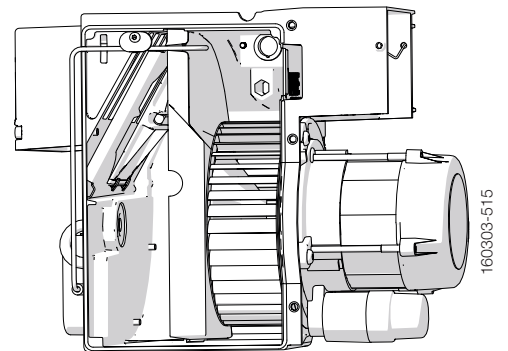
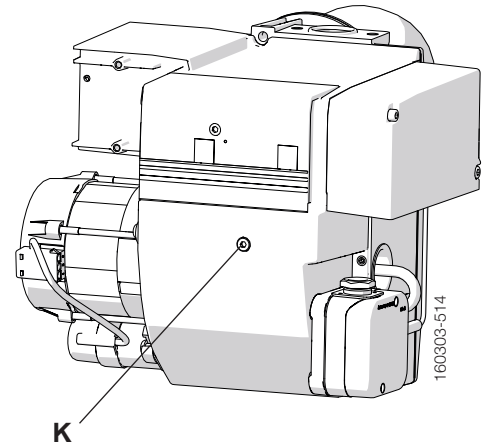

When servicing/replacing components that affect combustion, flue gas analysis and soot test shall be carried out on the installation.

5.4 Replacement of electrical components

1. Switch off the main power supply and turn off the gas.



Before obtaining access to terminals, all supply circuits must be disconnected.

2. Note the connection of the existing component and disassemble.
3. Mount a new component with the same connection or with the specified alternative connection.
4. Turn on the main power and check the function of the new component.
5. Start burner and check/adjust combustion.

5.5 Vibration

- Maximum vibration level is 5.0 mm/s.
- Check the correct tightening on all screws.
- Check fan wheel for damage and contamination. Replace damaged, contaminated or unbalanced impeller.
- Check motor shaft and bearings. If they are worn, replace the motor or bearing.

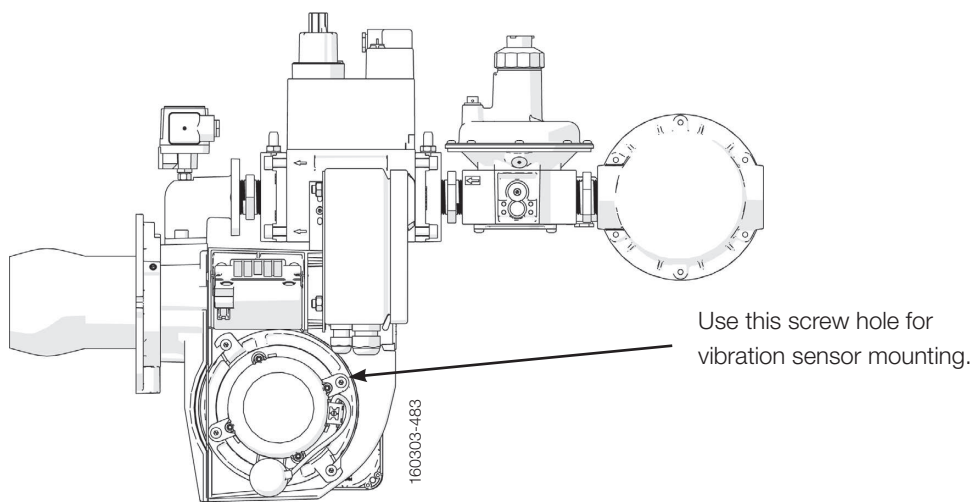

When servicing/replacing components that affect combustion, flue gas analysis and soot test shall be carried out on the installation.

5.6 Flame detector QRC

The current passing through the flame detector, when it is lit up, must be at least 70 μA . This current can be measured using a multimeter and needs to be performed if it is suspected that there is a malfunction.

Check the intensity of flame with the display AZL2. For system-specific reasons, the display of maximum flame intensity is limited to approx. 55%.

Limit values for flame monitoring with QRC ...:

- Start prevention (extraneous light) Approx. 15 μA , display approx. 10% Intensity of flame (parameter 954)
- Operation Approx. 25 μA , display approx. 16% Intensity of flame (parameter 954)

Required detector current (with flame)	Min. 70 μA
Permissible detector current (without flame)	Max. 5,5 μA
Typical detector current (with flame)	100 μA
Max temperature	60 °C

Measuring circuit for detector current measurement terminal X10-05

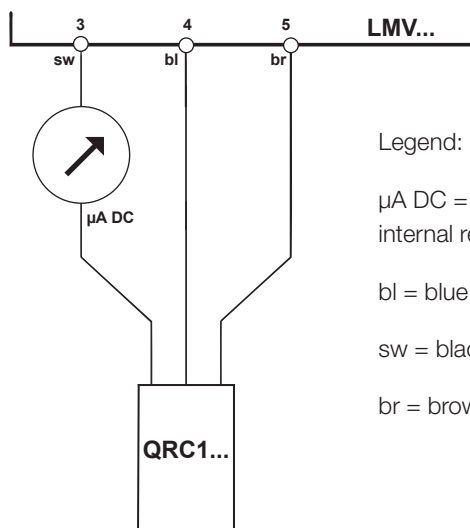

Legend:

$\mu\text{A DC}$ = DC-Mikroampèremeter an internal resistance of $R_i = \text{max. } 5 \text{ k}\Omega$

bl = blue

sw = black

br = brown

5.7 Burner Service Schedule, Gas

Servicing must be carried out once a year or after 3,000 hours of operation.

Burner	1 year	3,000 h
Inspection of electrical installation	1 year	3,000 h
Tightness check	1 year	3,000 h
Filter	1 year, replacement at $\Delta p > 10$ mbar	3,000 h, replacement at $\Delta p > 10$ mbar
Electrodes	Replacement/cleaning 1 year	Replacement/cleaning 3,000 h
Brake disc	Replacement/cleaning 1 year	Replacement/cleaning 3,000 h
Motor	1 year	3,000 h
Fan wheel	1 Year Replace if need for cleaning/ imbalance	3,000 h Replace if need for cleaning/imbalance

5.8 Component replacement intervals

Control system	10 years	250,000 starts
Valve control system	10 years	250,000 starts
Pressure switch	10 years	250,000 starts
Ignition system with flame guard	10 years	250,000 starts
UV flame sensor	10,000 h	N/A
Gas pressure controls	15 years	N/A
Gas valve without seal testing	10 years	250,000 starts
Gas valve with seal testing	Replacement upon fault detection	N/A
Gas pressure switch	10 years	250,000 starts
Safety blow-off system	10 years	N/A
Damper motor	N/A	500,000 starts
Contactors	10 years	500,000 starts



The burner and its components must be recycled according to applicable regulations.

6. Regulator RWF50

The burner must be connected to an external regulator.

Two variants of regulator for installation directly on the burner are available:

- Siemens RWF50.2 with 3-position signal (up signal, no signal and down signal).
- Siemens RWF50.3 with analogue signal 4-20 mA. LMV37 uses 4-20 mA.

For information and operation of the regulator, see the enclosed manual.



6.1 Connection of PT100 sensor

Minimum cable area is 0.5 mm².

X1:7	red
X1:8	blue
X1:9	blue

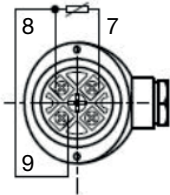

6.2 Operation

6.2.1 Meaning of display and buttons

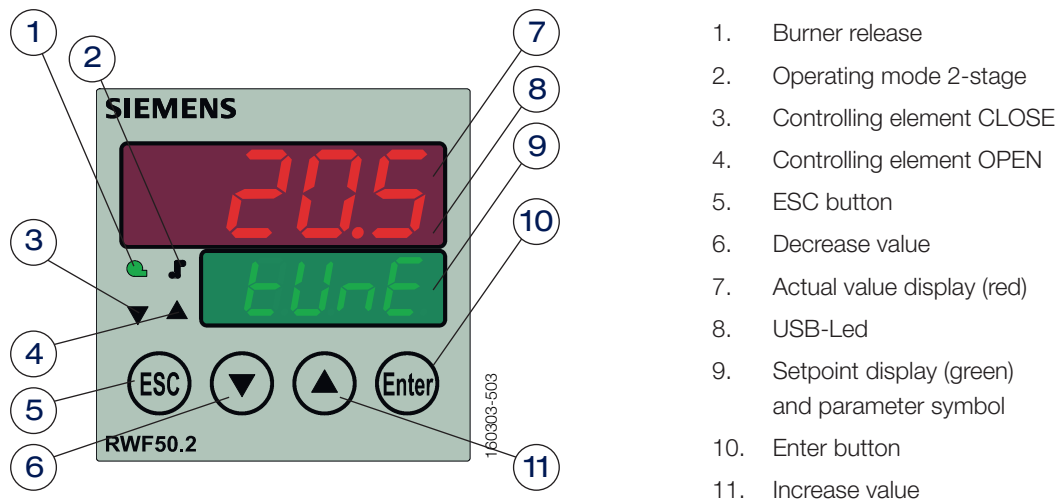

Initialization

The two 7-segment displays (red and green) show hyphens and all LEDs light up for about 5 seconds.

Basic display

The upper display (red) shows the actual value.
The lower display (green) shows the setpoint.

See chapter 8.6 Display diSP in the enclosed manual.

Parameter display

When entering parameters, the parameter symbol at the bottom (green) and the set value at the top (red) appear.

Self-setting function

The actual value is shown on the actual value display (red) and **tUnE** flashes on the setpoint display (green).

See chapter 9 Self-setting function in the enclosed manual.

Flashing actual value display

The actual value display (red) shows **9999** flashing.

See chapter 11 What to do if ... in the enclosed manual.

Manual control

The setpoint display (green) shows **HAnd** flashing.

See chapter 6.4 Manual control of a modulating burner in the enclosed manual.

6.3 Basic display

When switching power on, the displays show hyphens for about 5 seconds.

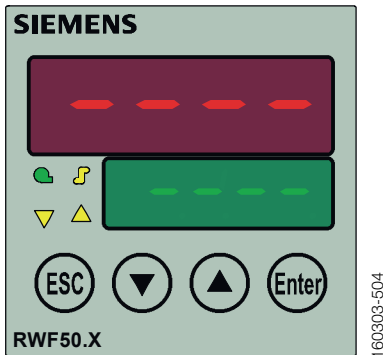

The state that follows is called normal display.

Default display is the actual value and the current setpoint.

Other values can be displayed at the configuration level or via PC software ACS411.

See chapter 8.6 Display diSP in the enclosed manual.

Manual control, self-setting, the user, parameter and configuration levels can be activated from here.

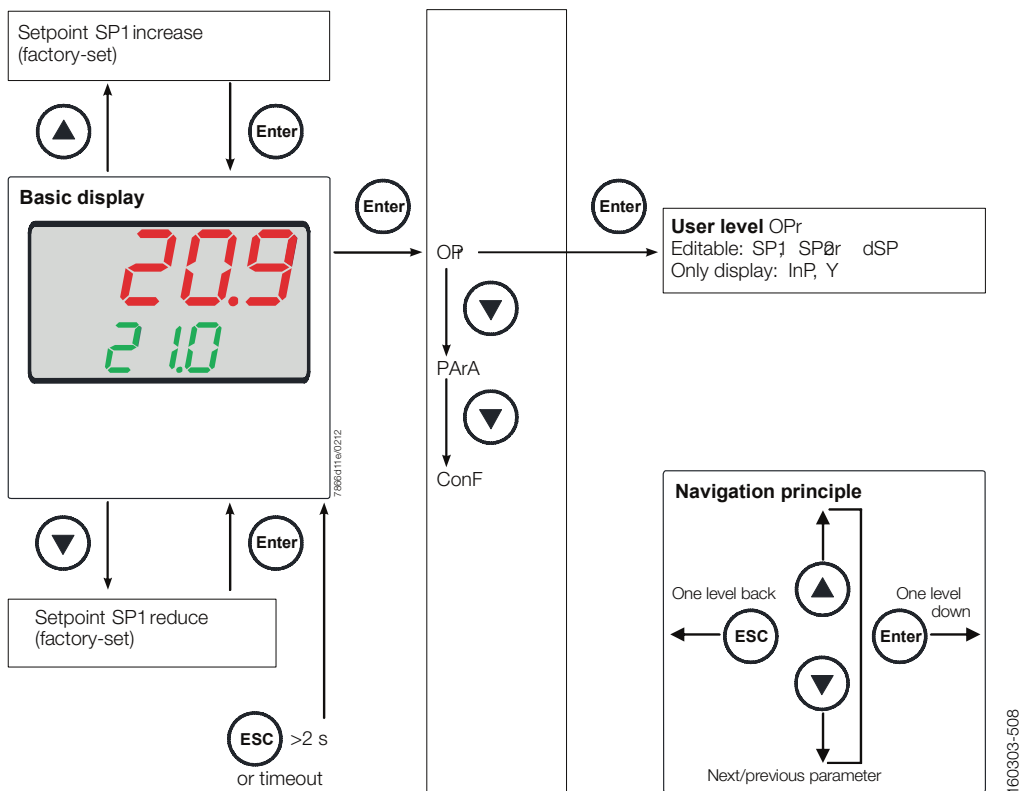

6.4 User level

This level is started from the basic display.

Setpoints SP1, SP2 or dSP can be altered.

Changing the setpoints

- From the basic display, press Enter so that **OPr** appears.
- Press Enter so that **SP1** appears.
- Press Enter and **SP1** flashes.
- Press ▲ or ▼ to adjust the required setpoint (temperature or pressure) and press Enter to confirm.

Timeout

Timeout after about 180 seconds.



If the setpoint is not stored, the basic display changes after the timeout tout and the former setpoint is maintained.

The value changes only within the permitted range.

6.5 Starting the self-setting function

Start

Press ▲ + ▼ for 5 seconds.

Cancel

Cancel with ▲ + ▼.

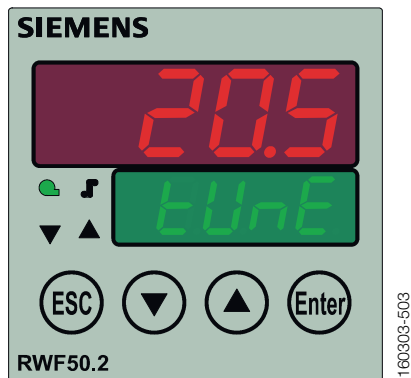

When **tUnE** stops flashing, the self-setting function has been ended.

The parameters calculated by the controller are automatically adopted!



It is not possible to start **tUnE** in manual control or low-fire operation.

6.6 Parameterization PArA

Here, set the parameters associated directly with the controller's adaptation to the controlled system after the plant has been put into operation.

! The display of the individual parameters depends on the type of controller.

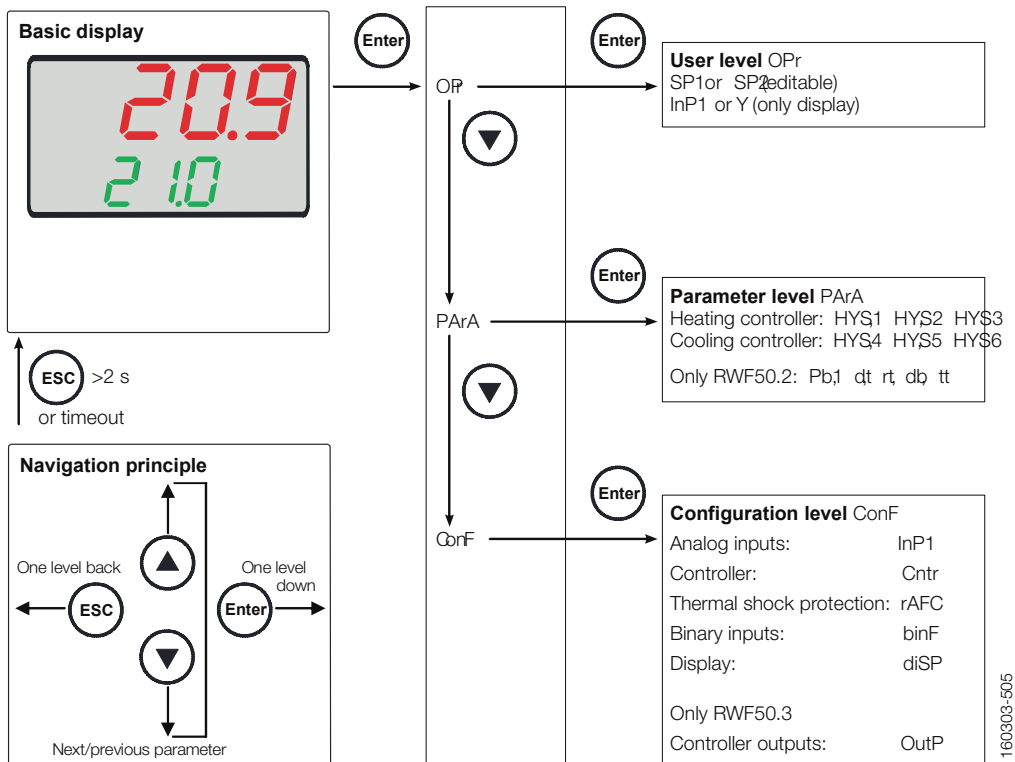

Access to this level can be locked.

See chapter 8.6 Display diSP in the enclosed manual.

- From the basic display, press Enter so that **OPr** appears.
- Press so that **PArA** appears.
- Press Enter so that the first parameter of the parameter level is displayed.

Display of controller parameters

The parameters are shown on the lower setpoint display (green) and their values on the upper/actual value display (red).



Parameter	Display	Value range	Factory setting	Remarks
Proportional band ¹	Pb1	1...9999 digit	10	Influences the controller's P-action
Derivative time	dt	0...9999 s	80	Influences the controller's D-action With dt = 0, the controller has no D-action
Integral action time	rt	0...9999 s	350	Influences the controller's I-action With rt = 0, the controller has no I-action
Dead band (neutral zone) ¹	db	0.0...999.9 digit	1	For 3-position output
Controlling element running time	tt	10...3000 s	15	Running time of the servo motor for use with modulating controllers
Switch-on threshold Heating controller ¹	HYS1	-1999...0.0 digit	-5	See chapter 5.2 High-fire operation in the enclosed manual.
Switch-off threshold stage II Heating controller ¹	HYS2	0.0...HYS3 digit	3	See chapter 5.2 High-fire operation in the enclosed manual.
Switch-off threshold Heating controller ¹	HYS3	0.0...9999 digit	5	See chapter 5.2 High-fire operation in the enclosed manual.
Switch-on threshold Cooling controller ¹	HYS4	0.0...9999 digit	5	See chapter 5.2 High-fire operation in the enclosed manual.
Switch-off threshold stage II Cooling controller ¹	HYS5	HYS6...0.0 digit	-3	See chapter 5.2 High-fire operation in the enclosed manual.
Switch-off threshold Cooling controller ¹	HYS6	-1999...0.0 digit	-5	See chapter 5.2 High-fire operation in the enclosed manual.
Response threshold	q	0.0...999.9	0	See chapter 5.5 Response threshold (q) in the enclosed manual.

¹ Setting of decimal place has an impact on this parameter.

! When using the RWF50... as a modulating controller only, or as a modulating controller without the burner release function (1P, 1N), parameter HYS1 must be set to 0 and parameters HYS2 and HYS3 must be set to their maximum values. Otherwise, for example, when using default parameter HYS1 (factory setting -5), the 3-position controller is only released when the control deviation reaches -5 K.

6.7 Configuration ConF

Here, the settings (e.g. acquisition of measured value or type of controller) required directly for commissioning a certain plant.

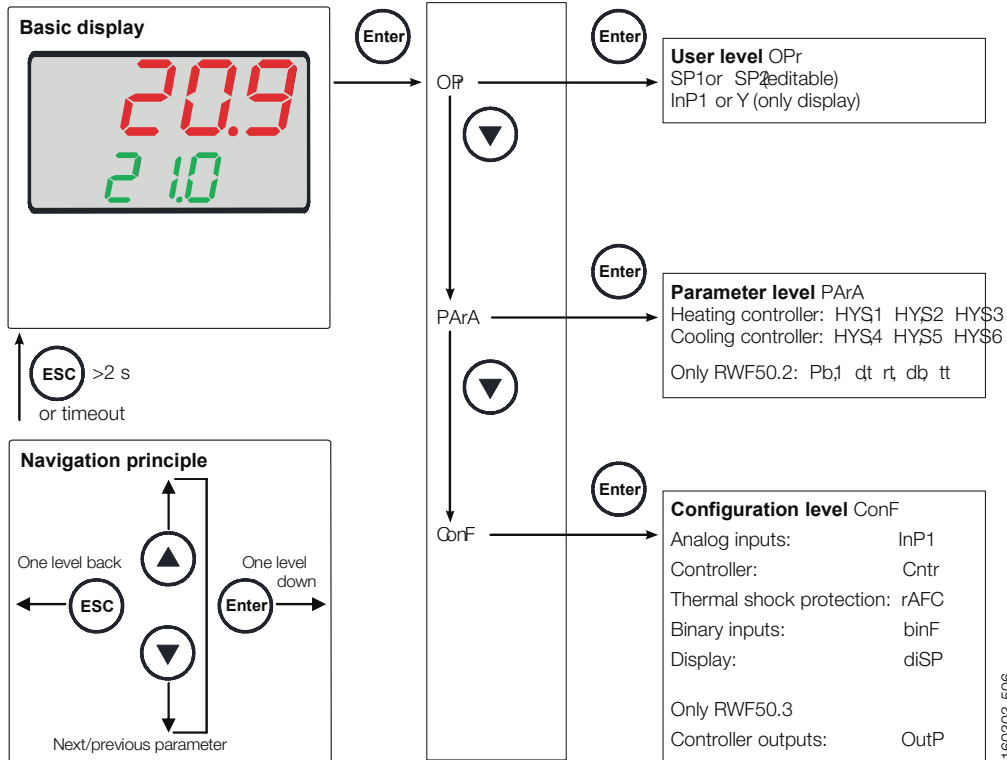

See chapter 8.6 Display diSP in the enclosed manual.

! The following tables show the default settings in columns Value/selection and Description in **bold** printing.

6.8 Analog input InP1

An analog input is available.

ConF → InP → InP1 →

Parameter	Value/ selection	Description									
Sensor type SEn1 Sensor type	1 2 3 4 5 6 7 15 16 17 18 19	Resistance thermometer Pt100, 3-wire Resistance thermometer Pt100, 2-wire Resistance thermometer Pt1000, 3-wire Resistance thermometer Pt1000, 2-wire Resistance thermometer LG-Ni1000, 3-wire Resistance thermometer LG-Ni1000, 2-wire 0...135 Ohm 0...20 mA 4...20 mA DC 0...10 V DC 0...5 V DC 1...5 V									
Correction of measured value OFF1 Offset	-1999... 0... +9999	Using the measured value correction (offset), a measured value can be corrected to a certain degree, either up or down. Example: <table border="1"> <thead> <tr> <th>Measured value</th> <th>Offset</th> <th>Displayed values</th> </tr> </thead> <tbody> <tr> <td>294.7</td> <td>+0.3</td> <td>295.0</td> </tr> <tr> <td>295.3</td> <td>-0.3</td> <td>295.0</td> </tr> </tbody> </table>	Measured value	Offset	Displayed values	294.7	+0.3	295.0	295.3	-0.3	295.0
Measured value	Offset	Displayed values									
294.7	+0.3	295.0									
295.3	-0.3	295.0									
<p>Caution! Measured value correction: To make the calculation, the controller uses the corrected value (displayed value). This value does not represent the value acquired at the point of measurement. If not correctly used, inadmissible values of the control variable can be produced. Measured value corrections must therefore be made within certain limits only.</p>											
Start of display SCL1 Scale low level	-1999... 0... +9999	In the case of a measuring transducer with standard signal, the physical signal is assigned a display value here. Example: 0...20 mA = 0...1500 °C									
End of display SCH1 Scale high level	-1999... 100... +9999	The range of the physical signal can be crossed by 20%, either up or down, without getting a signal informing about the crossing.									
Filter time constant dF1 Digital filter	0.0... 0.6... 100.0...	Is used to adapt the digital 2nd order input filter (time in s; 0 s = filter OFF). If the input signal changes abruptly, about 26% of the change are captured after a time corresponding to the filter time constant dF (2 x dF: approx. 59%; 5 x dF: approx. 96%) When the filter time constant is great: <ul style="list-style-type: none"> • Great attenuation of interference signals • Slow response of actual value display to changes of the actual value • Low limit frequency (low-pass filter) 									
Temperature unit Unit Temperature unit	1 2	Degrees Celsius Degrees Fahrenheit Unit of temperatures									

6.9 Controller Cntr

Here, the type of controller, operating action, setpoint limits and presettings for selfoptimization are selected.

ConF → Cntr →

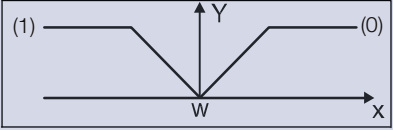
Parameter	Value/ selection	Description
Controller type CtYP Controller type	1 2	3-position controller (RWF50.2) Modulating controller (RWF50.3)
Operating action CACt Control direction	1 0	Heating controller Cooling controller  <p>(0) = cooling controller: The controller's angular positioning (Y) is >0 when the actual value (x) lies above the setpoint (w)</p> <p>(1) = heating controller: The controller's angular positioning (Y) is >0 when the actual value (x) lies below the setpoint (w)</p>
Setpoint limitation start SPL Setpoint limitation low	-1999... +9999	Setpoint limitation prevents values from being entered outside the end defined range.
Setpoint limitation end SPH Setpoint limitation high	-1999... +9999	
Self-optimization	0 1	Free Locked Self-optimization can only be disabled or enabled via the ACS411 setup program. If disabled via ACS411 PC software, self-optimization cannot be started via the controller's buttons. Setting in the ACS411 setup program → Controller → Self-optimization Self-optimization is also disabled when the parameter level is locked.
Lower working range limit oLLo Lower operation range limit	-1999... +9999	Note! If the setpoint with the respective hysteresis exceeds the upper working range limit, the switch-on threshold is substituted by the working range limit.
Upper working range limit oLHi Upper working range limit	-1999... +9999	Note! If the setpoint with the respective hysteresis drops below the lower working range limit, the switch-off threshold is substituted by the working range limit.

6.10 Thermal shock protection (TSS) rAFC

The RWF50... can be operated as a fixed value controller with or without ramp function.

ConF → rAFC →

Parameter	Value/ selection	Description
Function FnCt Function	0 1 2	Switched off Gradient Kelvin/minute Gradient Kelvin/hour Note! With FnCt = 1 or 2, Thermal shock protection (TSS) is automatically activated as soon as the actual value drops below the adjustable absolute limit value rAL (heating controller) or exceeds it (cooling controller).
Ramp slope rASL Ramp slope	0.0... 999.9	Slope of ramp slope (only with functions 1 and 2)
Tolerance band ramp toLP Tolerance band ramp	2 x HYS1 = 10...9999	Width of tolerance band (in K) about the setpoint (only with function 1 and 2). Heating controller: Smallest possible factory setting: 2 x HYS1 = 10 K To monitor the actual value in connection with thermal shock protection (TSS), a tolerance band can be laid about the setpoint curve. If the limit values are crossed, the ramp is stopped. See chapter 5.7 Thermal shock protection (TSS) in the enclosed manual. Cooling controller: Smallest possible factory setting: 2 x HYS4 = 10 K
<p>Note!</p> <p>In the event of a faulty sensor or manual control, the ramp function is stopped. The outputs behave the same way they do when the measuring range is crossed (configurable).</p> <p>Functions "Cold start of plant" and "Thermal shock protection (TSS)" are interlocked.</p> <p>Only one function can be activated, but never both at the same time.</p>		
Limit value rAL Ramp limit	0... 250	Heating controller: If the actual value lies below this limit value, the setpoint is approached in the form of a ramp until final setpoint SP1 is reached. Cooling controller: If the actual value lies above this limit value, the setpoint is approached in the form of a ramp until final setpoint SP1 is reached.

6.11 Control outputs OutP

With the RWF50.2, configuration of the outputs relates to the binary outputs (K2 and K3), and with the RWF50.3, to the analog outputs (A+ and A-). The burner is released via relay K1.

The switching states of relay K1 Burner release (LED green), relay K2 Controlling element OPEN, and relay K3 Controlling element CLOSE (yellow LED arrows) are indicated on the controller front.

Only RWF50.2... Binary outputs

The binary outputs of the RWF50.2 offer no setting choices.

Only RWF50.3... Analog output

The RWF50.3 has an analog output.

The analog output offers the following setting choices:

ConF → OutP →

Parameter	Value/ selection	Description
Function	1	Analog input InP1 is delivered
FnCt	4	Controller's angular positioning is delivered (modulating controller)
Function		
Signal type	0	0...20 mA
SiGn	1	4...20 mA
Type of signal	2	DC 0...10 V
		Physical output signal
Value when out of range	0...101	Signal (in percent) when measuring range is crossed
rOut		101 = last output signal
Value when out of range		
Zero point	-1999...	A value range of the output variable is assigned to a physical output signal
OPnt	0...	
Zero point	+9999	
End value	-1999...	
End	100...	
End value	+9999	

6.12 Binary input binF

This setting decides on the use of the binary input.

See chapter 5.4 Predefined setpoint in the enclosed manual.

ConF → binF →

Parameter	Value/ selection	Description
Binary input	0	No function
bin1	1	Setpoint changeover
Binary inputs	2	Setpoint shift
	4	Changeover of operating mode
		Burner modulating: Contacts D1 and DG open
		Burner 2-stage: Contacts D1 and DG closed

6.13 Display diSP

By configuring the position of the decimal point and automatic changeover (timer), both LED indications can be adapted to the respective requirements. Timeout tout for operation and the locking of levels can be configured as well.

ConF → diSP →

Parameter	Value/ selection	Description
Upper display diSU Upper display	0 1 4 6 7	Display value for upper display Switched off Analog input InP1 Controller's angular positioning Setpoint End value with thermal shock protection
Lower display diSL Lower display	0 1 4 6 7	Display value for lower display Switched off Analog input InP1 Controller's angular positioning Setpoint End value with thermal shock protection
Timeout tout	0... 180... 255	Time (s) on completion of which the controller returns automatically to the basic display, if no button is pressed.
Decimal point dECP Decimal point	0 1 2	No decimal place One decimal place Two decimal places If the value to be displayed cannot be shown with the programmed decimal point, the number of decimal places is automatically reduced. If the measured value drops again, the number of decimal places is increased until the programmed value is reached
Locking of levels CodE	0 1 2 3	No locking Locking of configuration level Locking of parameter level Locking of keyboard

7. Automatic control unit LMV37

The LMV37 automatic control unit is a piece of control equipment that can be used for many different types of burner.

In the following review of how this control equipment works and can be adjusted, the description will focus on the type of burner covered by this

7.1 System structure/function description

The LMV37.4... is a microprocessor-based burner management system with matching system components for the control and supervision of forced draft burners of medium to high capacity.

Integrated in the basic unit of the LMV37.4... are:

- Burner management system complete with valve proving system
- Electronic air-fuel ratio control system for a maximum of 2 SQM3... or SQN1... actuators
- Control of VSD air fan
- Modbus interface

At the time of writing, of the parameters mentioned above, motor frequency control and communication via modbus are not available on the burner models described in this manual.

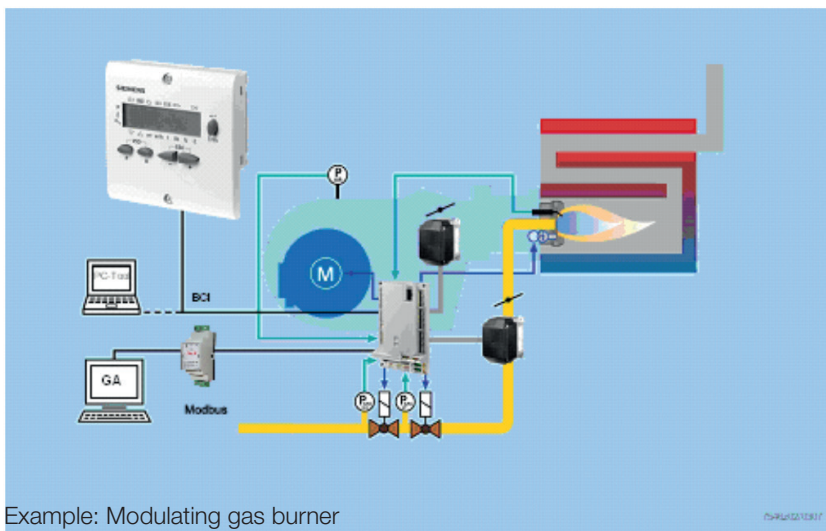

The system components (display and operating unit, actuators) are connected directly to the LMV37.4... basic unit. All safety-related digital inputs and outputs of the system are monitored by a contact feedback network.

7.2 General information

The burner management system is operated and parameterized via the AZL2... display. The AZL2... with LCD and menu-driven operation facilitates straightforward use and targeted diagnostics. When making diagnostics, the display shows the operating states, the type of error and the point in time the error occurred. Passwords protect the different parameter levels of the burner against unauthorized access. It is possible to select from different types of fuel trains and make use of a wide choice of individual parameter settings (program times, configuration of inputs / outputs, etc.), enabling the installer to make optimum adaptations to the relevant application. A change of parameters varies in levels of authorization, this manual will give info on those that might be changed by the installer. The actuators are driven by stepper motors and can be positioned with high resolution. Specific features and actuator settings are defined by the LMV37.4... basic unit.

7.3 Technical Data Basic unit LMV37.4...

Mains voltage	
LMV37.400A2	AC 230 V -15 % / +10 %
Mains frequency	50 / 60 Hz \pm 6 %
Safety class	I, with parts according to II and III to DIN EN 60730-1
Perm. mains primary fuse (externally)	Max. 5 AT
Unit fuse F1 (internally)	6.3 AT (DIN EN 60127 2 / 5)
Mains supply: Input current depending on the operating state of the unit	

Under voltage	
Safety shutdown from operating position at mains voltage	
LMV37.400A2	Approx. AC 186 V
Restart on rise in mains voltage	
LMV37.400A2	Approx. AC 195 V

Gas direct ignition «G», «G mod», «G mod pneu»

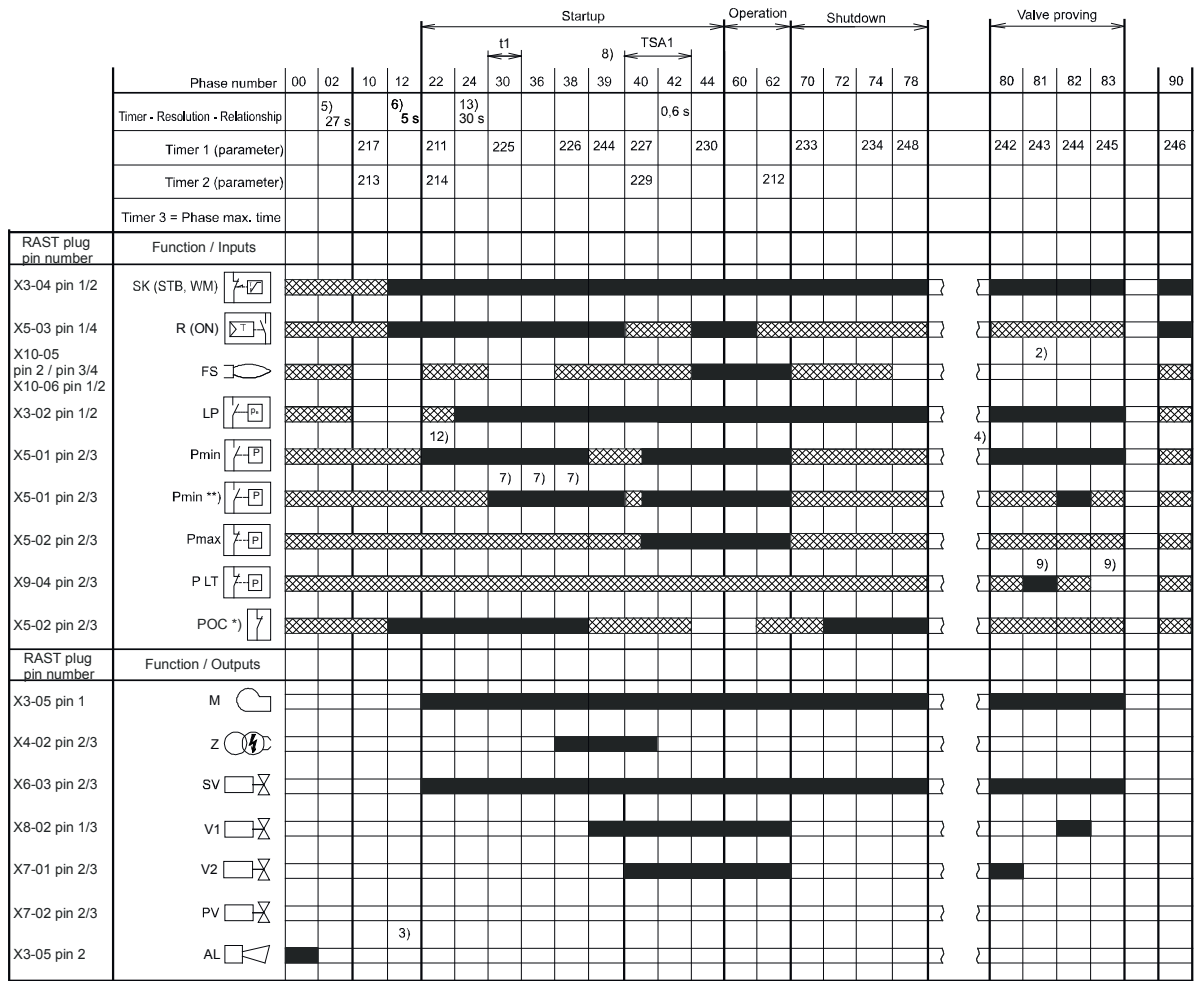





Legend to the sequence diagrams



Not all phases, times, indices, abbreviations and symbols appear in the individual sequence diagrams or are needed there!

Phase numbers

00	Lockout phase
02	Safety phase
10	Home run
12	Standby (stationary)
22	Fan motor (M) = ON, safety valve (SV) = ON
24	Air damper (LK)  fuel valve (V) – position
30	Prepurging
36	Air damper (LK)  ignition (Z) – position
38	Preignition ignition (Z) = ON
39	Test pressure switch-min (Pmin)
40	Fuel valve (V) = ON
42	Ignition (Z) = OFF
44	Interval 1 (t44)
50	Safety time 2 (TSA2)
52	Interval 2 (t52)
60	Operation 1 (stationary)
62	Operation 2 air damper (LK)  low-fire (KL) – position
70	Afterburn time (t13)
72	Air damper (LK)  Rated load (NL) – position
74	Postpurge time (t8)
78	Postpurge time (t3)
80	Evacuation of test space
81	Atmospheric pressure test
82	Filling of test space
83	Gas pressure test
90	Gas shortage waiting time

Valve proving is performed depending on the parameter settings:
Simultaneously with the prepurge time and/or the afterburn time.

Times

TSA1	1st safety time
t1	Prepurge time
t3	Postpurge time
t8	Postpurge time
t13	Afterburn time
t44	Interval 1
t52	Interval 2

Indices

1)	Parameter:	Short/long prepurge time for oil only Short/long on time of oil pump – time
2)		Only with valve proving during startup
3)	Parameter:	With/without alarm in the event of start prevention
4)		If signal is faulty in the startup phase, phase 10 is next, otherwise phase 70
5)		Max. time safety phase, then lockout
6)		Time from occurrence of start prevention to signaling
7)		Only in case of valve proving during startup (valve proving via pressure switch-min)
8)		Only in case of startup without valve proving (valve proving via pressure switch -min)
9)		Inverse logic in case of valve proving via pressure switch-min
10)	Parameter:	Oil pressure min-input 1 = active from phase 38 2 = active from safety time
11)		Only with fuel train Lo and 2 fuel valves
12)	Parameter 223:	Repetition limit value gas pressure switch-min in connection with gas shortage program parameter 246 (phase 90)
13)		Max. drop-in/response time for air pressure switch
14)		Alternative to valve proving
15)		Alternative to pressure switch-max (Pmax) or POC

Abbreviations

AL	Alarm
FS	Flame signal
GM	Fan motor contactor
LP	Air pressure switch
M	Fan motor
P LT	Pressure switch for valve proving
Pmax	Pressure switch-max
Pmin	Pressure switch-min
POC	Proof of closure
PV	Pilot valve
R	Temperature or pressure controller
SB	Safety limiter
SK	Safety loop
STB	Safety limit thermostat
SV	Safety valve
WM	Water shortage
V1	Fuel valve 1
V2	Fuel valve 2
VP	Combustion pressure switch
Z	Ignition transformer
SA	Actuator
SA-K	Low-fire position of actuator
SA-N	Postpurge position of actuator
SA-R	Home position of actuator
SA-V	Rated load position of actuator
SA-Z	Ignition load position of actuator

Symbols



Permissible position range



In Standby mode: Actuator is allowed to travel within the permissible position range, but is always driven to the home position; must be in the home position for phase changes

0°/10%

Position as supplied (0°)

90°/100%

Actuator fully open (90°)



Input/output signal 1 (ON)

Input/output signal 0 (OFF)

Input permissible signal 1 (ON) or 0 (OFF)

7.4 Connection and internal diagram

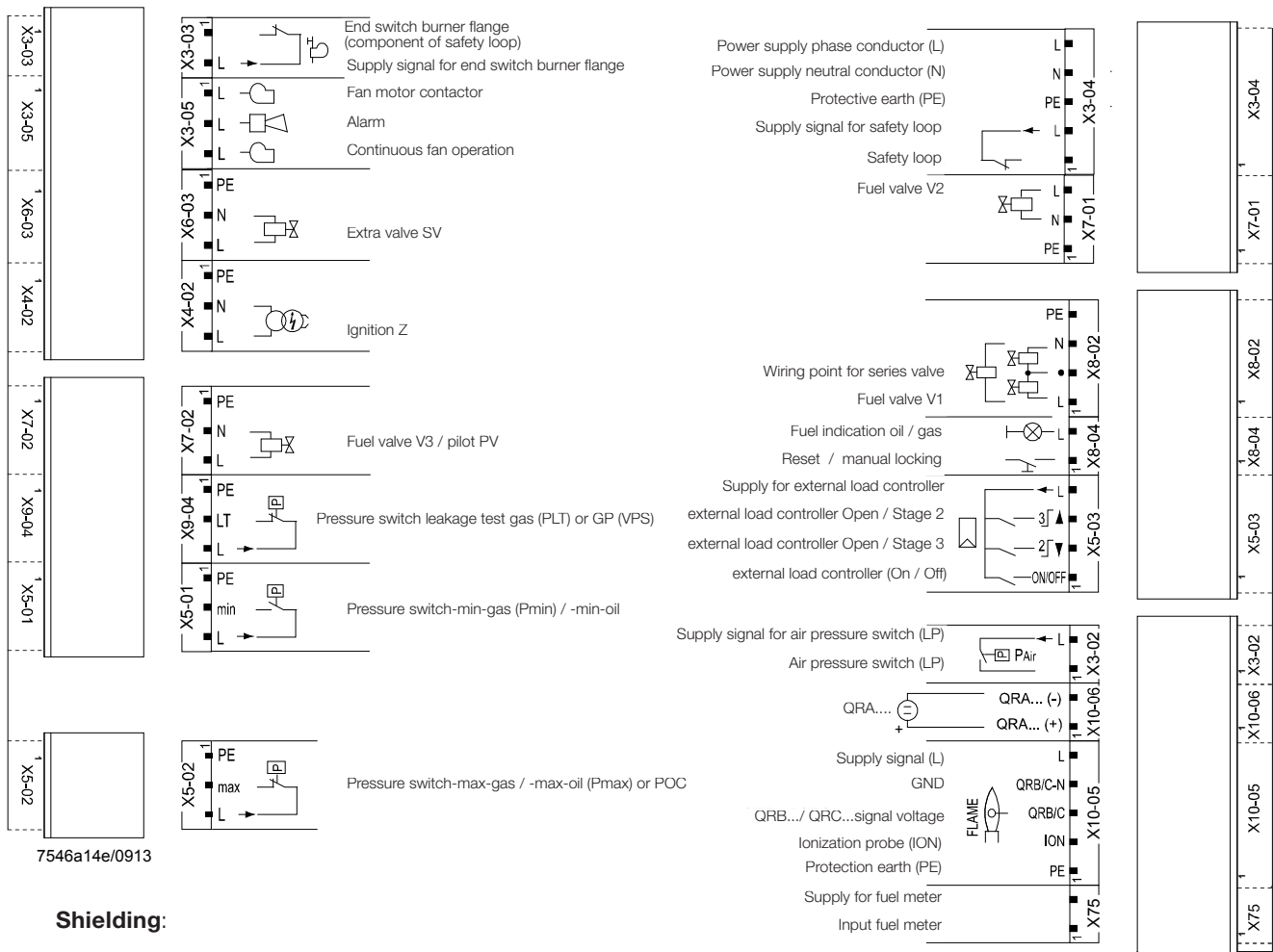

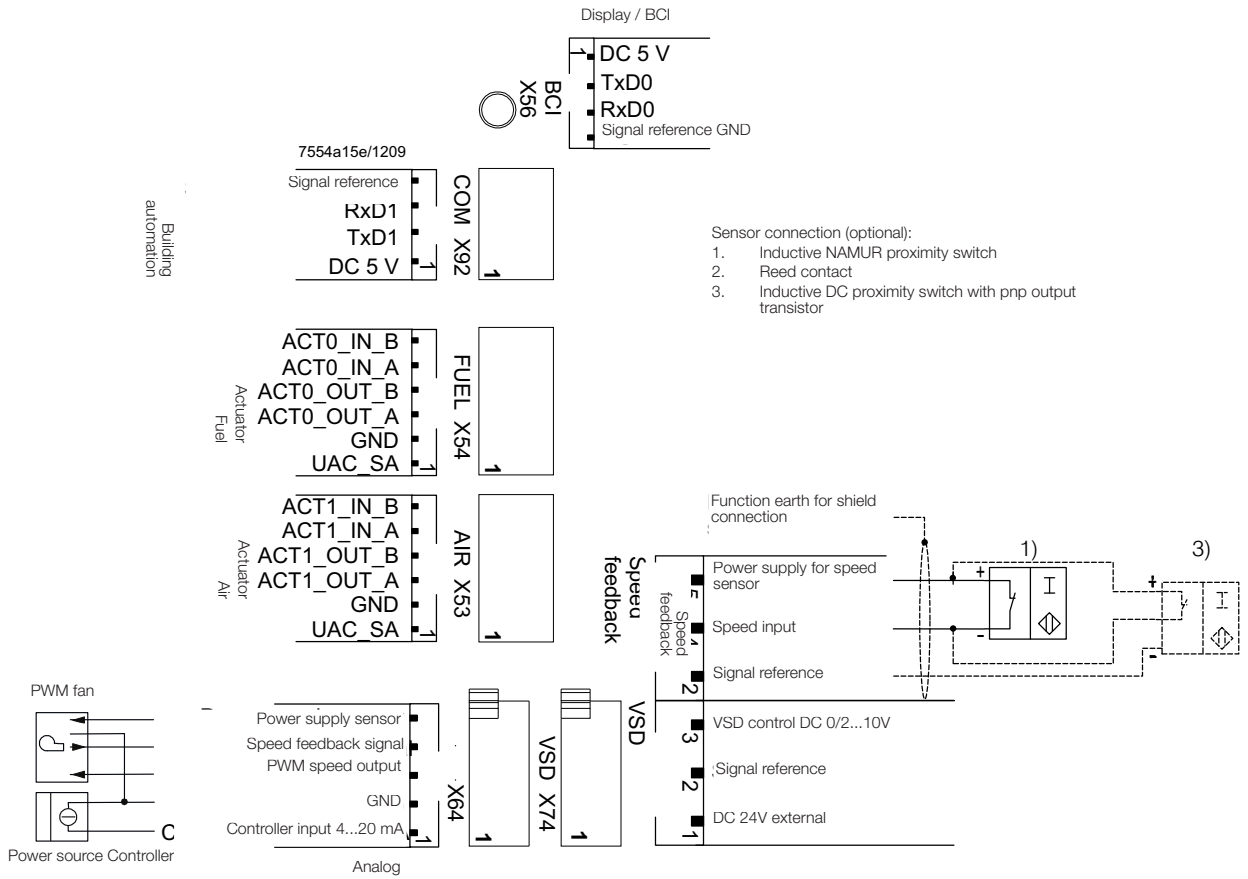

8. Operation

8.1 LMV37 automatic control unit

8.1.1 Explanation of display and buttons AZL2

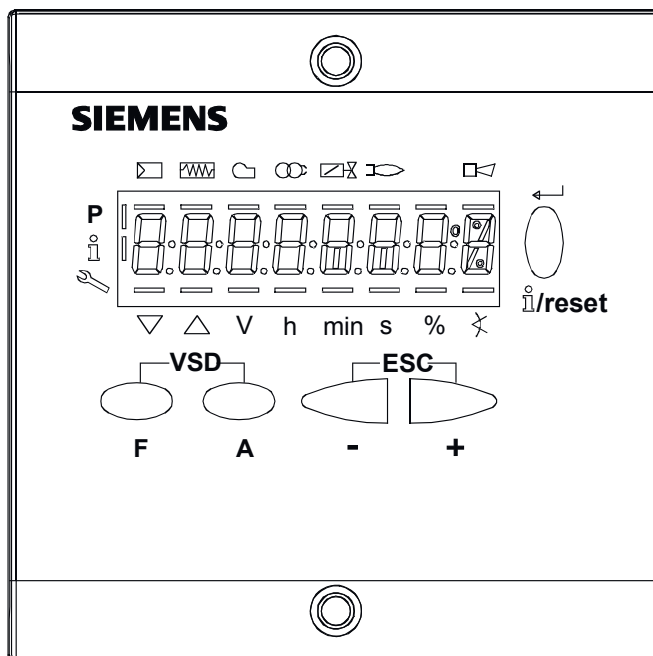







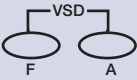

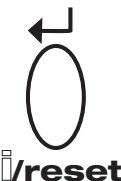

Figure 3: Description of unit/display and buttons

Button	Function
	<p>Button F</p> <p>- For adjusting the fuel actuator</p> <p>(keep  depressed and adjust the value by pressing  or </p>
	<p>Button A</p> <p>- For adjusting the air actuator</p> <p>(keep  depressed and adjust the value by pressing  or </p>
	<p>Buttons A and F: VSD function</p> <p>- For changing to parameter setting mode P</p> <p>(press simultaneously  and </p>
	<p>Info and Enter button</p> <ul style="list-style-type: none"> - For navigating in info or service mode • Selection (symbol flashing) (press button for <1 s) • For changing to a lower menu level (press button for 1...3 s) • For changing to a higher menu level (press button for 3...8 s) • For changing the operating mode (press button for >8 s) - Enter in parameter setting mode - Reset in the event of fault - One menu level down





Button	Function
	- button <ul style="list-style-type: none"> - For decreasing the value - For navigating during curve adjustments in info or service mode
	+ button <ul style="list-style-type: none"> - For increasing the value - For navigating during curve adjustments in info or service mode
	+ and - button: Escape function (press  and  simultaneously) <ul style="list-style-type: none"> - No adoption of value - One menu level up

Figure 4: Meaning of display



8.2 List of phase displays

The display shows which phase the burner is in. The table below lists the codes and explains what these mean for the various phases. Not all the phases described in the table are shown or are suitable for the burners described in this manual.

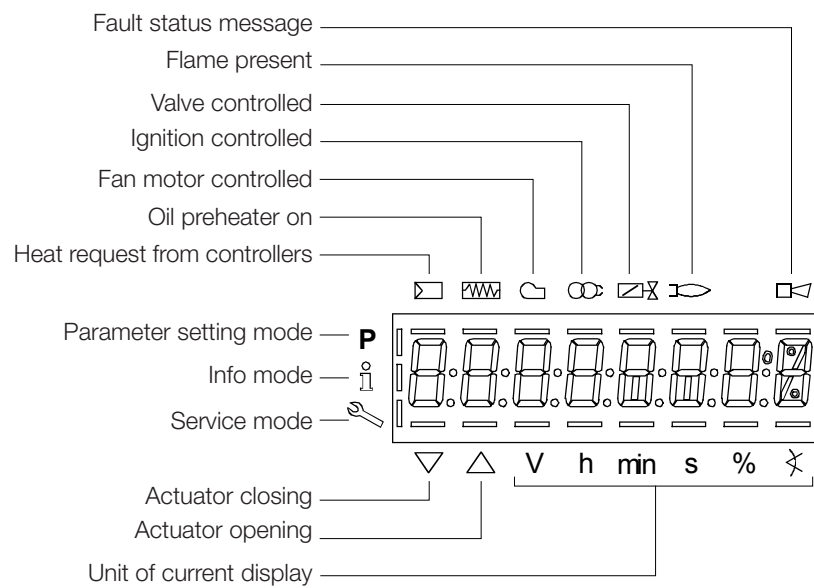
Phase	Function
Ph00	Lockout phase
Ph01	Safety phase
Ph10	Home run
Ph12	Standby (stationary)
Ph22	Fan ramp up time (fan motor = ON, safety valve = ON)
Ph24	Traveling to the prepurge position
Ph30	Prepurge time
Ph36	Traveling to the ignition position
Ph38	Preignition time
Ph39	Valve proving filling time (test of pressure switch-min when fitted between fuel valves V1 and V2)
Ph40	1st safety time (ignition transformer ON)
Ph42	1st safety time (ignition transformer OFF)
Ph44	Interval 1
Ph50	2nd safety time
Ph52	Interval 2
Ph60	Operation 1 (stationary)
Ph62	Max. time low-fire (operation 2, preparing for shutdown, traveling to low-fire)
Ph64	Switching back to pilot: Modulation to ignition load
Ph65	Switching back to pilot: Interval 2 waiting time
Ph66	Switching back to pilot: Reactivation of ignition + pilot
Ph67	Switching back to pilot: Shutdown of main valves
Ph68	Switching back to pilot: Pilot mode waiting phase
Ph69	Switching back to pilot: Pilot mode waiting phase for burner startup
Ph70	Afterburn time
Ph72	Traveling to the postpurge position
Ph74	Postpurge time (no extraneous light test)
Ph78	Postpurge time (t3) (abortion when load controller ON)
Ph80	Valve proving test evacuation time
Ph81	Valve proving test time atmospheric pressure, atmospheric test
Ph82	Valve proving filling test, filling
Ph83	Valve proving time gas pressure, pressure test
Ph90	Gas shortage waiting time

8.3 Automatic control unit levels

When working on burners there are different levels at which the automatic control unit can be accessed.

The info and service levels can be accessed without a password; error codes, error history and basic information about the burner can be viewed on these levels.

A code is required to enter settings for the burner.

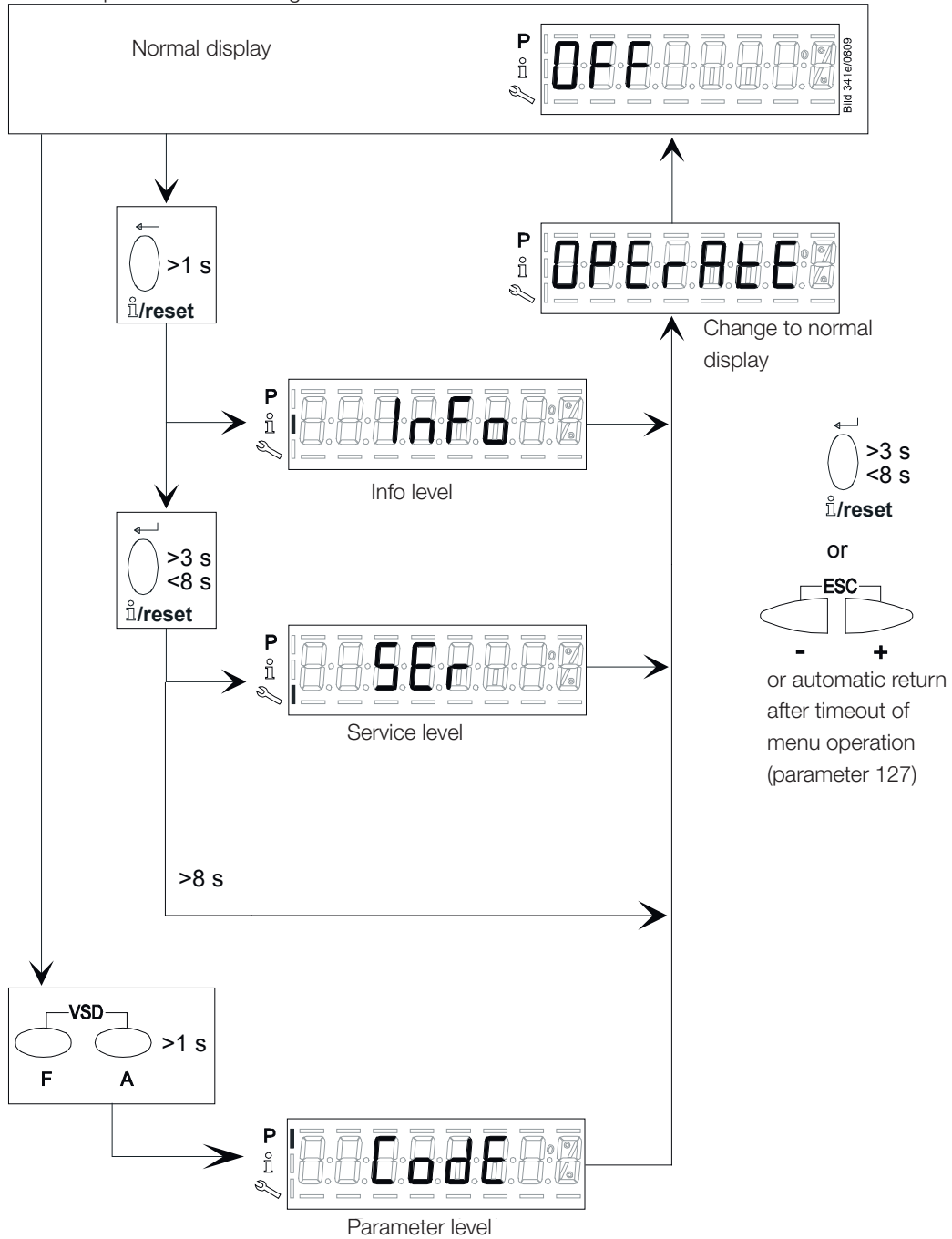

8.3.1 Structure of parameter levels



Bild 388e/1109

! The following sections explain the operating philosophy behind the parameter levels using a number of examples.

8.3.2 Parameter of level info

No.	Parameter
167	Fuel volume resettable (m ³ , l, ft ³ , gal)
162	Operating hours resettable
164	Startups resettable
163	Operating hours when unit is live
166	Total number of startups
113	Burner identification
107	Software version
108	Software variant
102	Identification date
103	Identification number
104	Preselected parameter set: Customer code
105	Preselected parameter set: Version
143	Reserve
End	

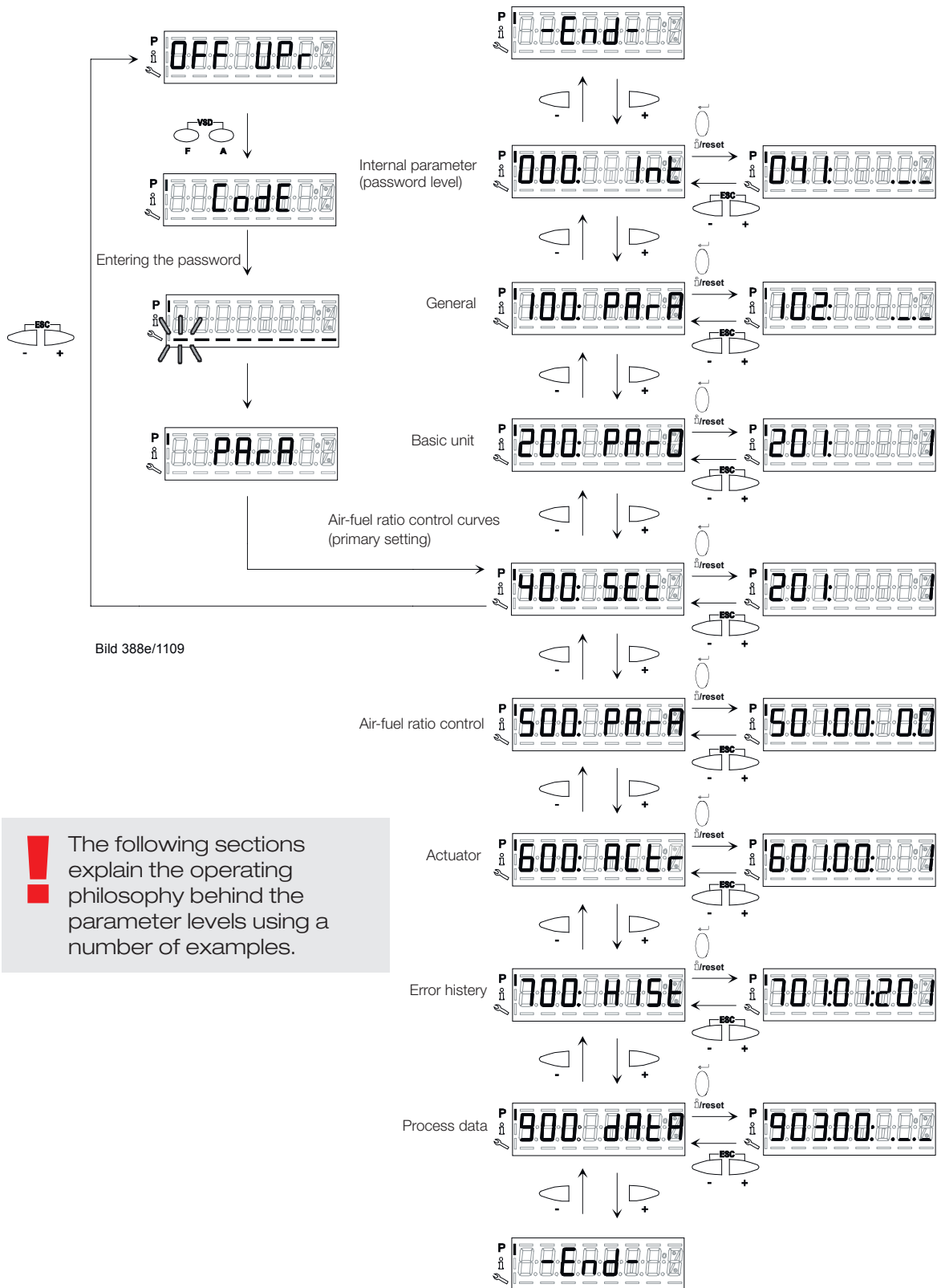
8.3.3 Parameter of level service

No.	Parameter
954	Flame intensity
960	Actual flow rate (fuel throughput in m ³ /h, l/h, ft ³ /h, gal/h)
121	Manual output
	Undefined = automatic operation
922	Incremental position of actuators
	Index 0 = fuel
	Index 1 = air
936	Standardized speed
161	Number of faults
701	Error history: 701-725.01.Code
	ex. 701. 01. xxx
	↑ ↑ ↑
	chronological error list index value of index
	.
	.
	.
725	

Index list:

01 = error code	04 = error phase
02 = diagnostic code	05 = startup counter
03 = error class	06 = output

8.3.4 Access code for service engineer level

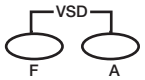

! The code for logging into service level is found on the plate on the inside of the cover for the electrical connections box.

Press button combination  to display **Code**

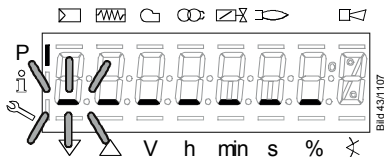

When releasing the buttons, 7 bars appear the first of wishes.



Press  or  to select a number or letter.

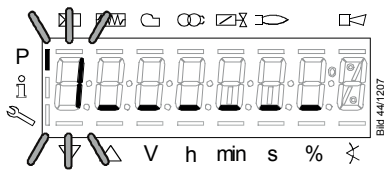

Press  to confirm the value

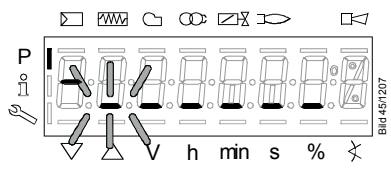

The value entered changes to a minus sign (-)
The next bar starts flashing.

Complete the rest of the password according to the principle described.

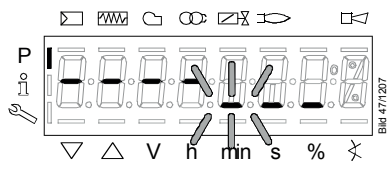

Example: Password consisting of 4 characters.

After entry of the last character the password must be confirmed by pressing



8.4 Setting the automatic control unit

To set the correct ratio between air and fuel, it is important to understand how this type of burner is controlled. This chapter will describe the procedure to follow when adjusting a burner with an LMV37 automatic control unit.

Note! When power is turned on for an unadjusted automatic control unit, **"OFF UPr"** is always shown in the display.

8.3.5 Setting an automatic control unit which has not previously been set or lost its settings

Check that the burner is receiving power and that gas is being supplied to the burner.

Turn the switch (X) to ON position, the text **"OFF UPr"** is shown in the display.

Turn the switch (Y) to ON position.

Follow the procedure indicated below to set the automatic control unit.

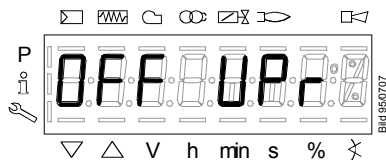
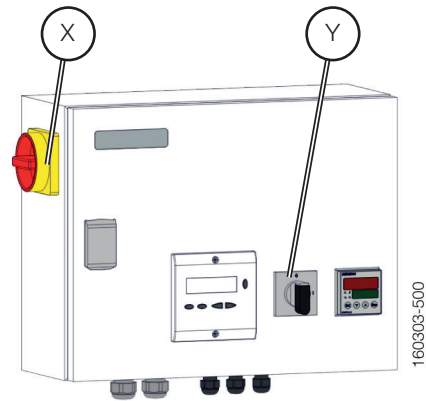

An unprogrammed unit or a unit whose operating mode has been reset or changed displays **OFF UPr**.



Press **F** **A** > 1 second to access login mode.

To continue with the setting work, you need to log into service engineer level. See 5.3.4.

After login is complete, continue with the setting work as shown below.

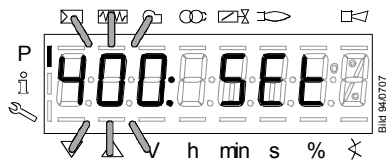

Press  to select parameter **400** for initial commissioning and for setting air-fuel control.

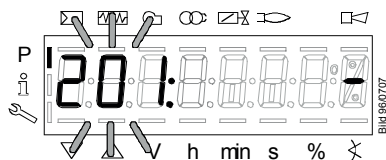

201: appears flashing.

Press to go to the settings for air-fuel ratio control and parameter

201 for selecting the operating mode.



Ensure that the fuel train is correctly set in compliance with the type of burner used.

No	Parameter	Actuator controlled	
		Air	Fuel
201	Burner operating mode (fuel train, modulating / multistage, actuators, etc.)	Air	Fuel
	-- = undefined (delete curves)	•	•
	1 = gas modulating (G mod)	•	•
	2 = gas modulating with pilot valve (Gp1 mod)	•	•
	3 = gas modulating with pilot valve (Gp2 mod)	•	•
	4 = oil modulating (Lo mod)	•	•
	5 = oil 2-stage (Lo 2 stage)	•	-
	6 = oil 3-stage (Lo 3 stage)	•	-
	7 = gas modulating (G mod pneu)	•	-
	8 = gas modulating (Gp1 mod pneu)	•	-
	9 = gas modulating (Gp2 mod pneu)	•	-
	10 = oil modulating with gas pilot (LoGp mod)	•	•
	11 = oil 2-stage with gas pilot (LoGp 2-stage)	•	-
	12 = oil modulating with 2 fuel valves (Lo mod 2V)	•	•
	13 = oil modulating with gas pilot and 2 fuel valves (LoGp mod 2V)	•	•
	14 = gas modulating (G mod pneu, 0 active)	-	-
	15 = gas modulating with pilot (Gp1 mod pneu, 0 active)	-	-
	16 = gas modulating with pilot (Gp2 mod pneu, 0 active)	-	-
	17 = oil 2-stage (Lo 2-stage, 0 active)	-	-
	18 = oil 3-stage (Lo 3-stage, 0 active)	-	-
	19 = gas modulating only when firing on gas (G mod fuel active)	-	•
	20 = gas modulating with pilot only when firing on gas (Gp1 mod fuel active)	-	•
21 = gas modulating with pilot only when firing on gas (Gp2 mod fuel active)	-	•	
22 = oil modulating only when firing on oil (Lo mod fuel active)	-	•	



This manual describes “14=gas modulating (Gmod)” type burners (without damper motor).

Press: to return to parameter level.

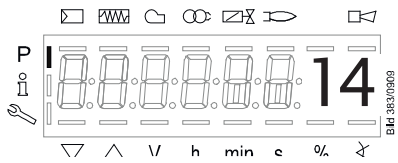

Press to save selected setting.

Press: to return to parameter level.

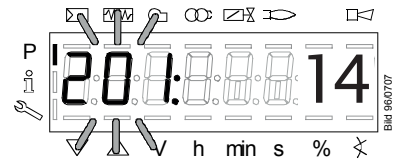

To the next parameter

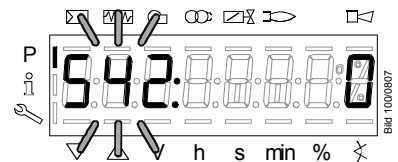

Parameter **542** to activate the VSD / PWM fan.
Choose:
0 = VSD / PWM fan OFF

If the parameter is set correctly, move directly to the next parameter with

Press to adjust parameter **542**.

Select your setting by pressing one of the buttons

Press to save the setting for parameter **542**: VSD

Press: to return to parameter level.

This manual describes “0=VSD OFF” type burners.

To the next parameter Back to the previous parameter

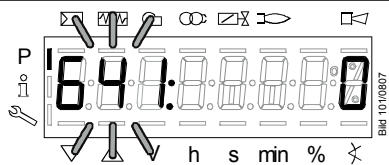



Parameter **641** to control speed standardization of the VSD.



Choose:
0 = speed standardization of VSD OFF

If the parameter is set correctly, move directly to the next parameter with 

Press:  to adjust parameter **641**: speed standardization

Select your setting by pressing one of the buttons  

Press:  to save the setting for parameter **641**: VSD

Press:    to return to parameter level.

 This manual describes "0=speed standardization" type burners.

Go to the next parameter with 

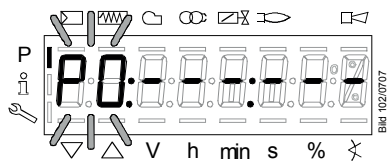

Display **P0** appears flashing.

Fuel/air settings are not made in the display but on the respective component on the burner, see chapter "Burner settings".

Go to **P9** with .

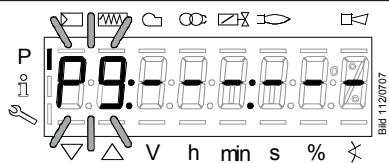

Display **P9** appears flashing.

Press  to start the burner.

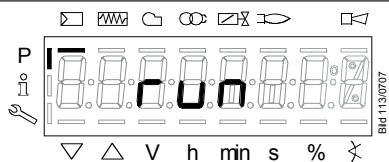

Identification of start for setting the curve parameters.

Press  to continue.

The burner motor will then start and a number of phases in the automatic control unit are completed.

If the switch on the burner is in the OFF position, the automatic control unit will not proceed from **Ph12**: Move the switch to the **ON** position to continue.

	Phase Standby (stationary)
	Phase Fan ramp up (fan motor = ON, safety valve = ON)
	Phase Traveling to prepurge position
	Phase Prepurging
	Phase Traveling to ignition position
	Phase Preignition
	Phase for first safety time (ignition transformer ON)
	Phase for first safety time (ignition transformer OFF), preignition time OFF
	Phase Interval 1

The burner has ignited and is burning.

Should the burner not ignite, repeat the above procedure by adjusting the fuel / air settings on the respective component on the burner, see chapter "Burner settings".

The P0 menu will appear when the burner starts successfully, step from P0 to P9 with .

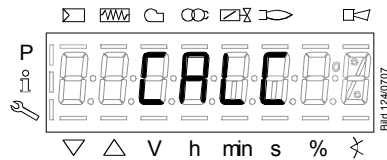

CALC appears for a short moment.

When **P9** flashes, press  simultaneously.

! If the burner goes into blocking mode when increasing to full load, restart the setting procedure and adjust the curvepoints in order to avoid the burner entering blocking mode.

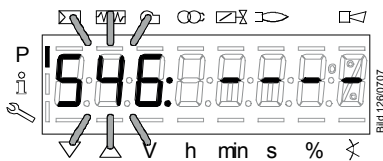

The maximum capacity is displayed.

If the display shows - - - -, the maximum capacity has not yet been specified.

The system can be run up to 100%.

You can press  to go to editing mode, enabling you to change the maximum capacity.

Adjust the setting downwards or upwards using the buttons .

Press  to save the setting.

Press  to return to parameter level.

To the next parameter 

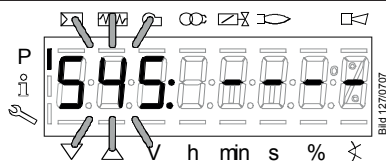

The minimum capacity is displayed.
If the display shows - - - , the minimum capacity has not yet been entered.
The system can be run down to 20%.

You can press  to go to editing mode, enabling you to

change the minimum capacity.

Adjust the setting downwards or upwards using the buttons 



Press  to save the setting.



Press  to return to parameter level.

Completing parameterization of the curve  Back to the previous parameter 

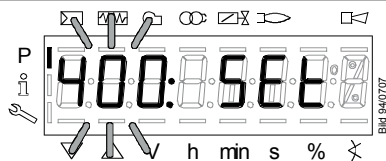

Press  to exit parameter level.

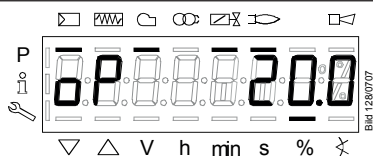

The settings for air-fuel ratio control by the LMV37... are now completed.

8.4.1 The parameters below may need to be set according to the nature of the installation.

To change any of the parameters set out below, go into parameter level and make the required adjustments.

8.4.1.1 Pressure switch-min input

236 Gas: Pressure switch-min input

0 = inactive

1 = pressure switch-min (upstream of fuel valve 1)

(Factory settings marked with bold text).

8.4.1.2 Execution valve proving

241 Gas: Execution valve proving

0 = no valve proving

1 = valve proving on startup

2 = valve proving on shutdown

3 = valve proving on startup and shutdown

(Factory settings marked with bold text).

 Depending on the type of burner, the automatic control unit should be set to either “0=no valve proving” or “1=valve proving on startup”.

At an input power higher than 1,200 kW, a tightness test must be performed.

At an input power lower than 1,200 kW, performing a tightness test is optional. It is essential for all changes to take local standards and regulations into consideration.

8.4.1.3 Active detector flame evaluation

221 Gas: Active detector flame evaluation

0 = QRB / QRC

1 = ION / QRA

(Factory settings marked with bold text).

When replacing detector flame between ionisation and UV-cell (QRA), no change to the setting parameters is required; simply disconnect and connect ionisation and UV-cell (QRA) respectively..

8.4.1.4 Prepurging

222 Gas: Prepurging

Index 0 = deactivated

Index 1 = activated

(Factory settings marked with bold text).

When using valve proving and 2 fuel valves of class A, prepurging is not required (conforming to EN 676).

If not activated, it is nevertheless performed if one or several of the following conditions apply:

- Alterable lockout position
- After an off time of >24 hours
- In the event of a power failure (power-on)
- In the event of shutdown due to an interruption of gas supply (safety shutdown)

8.4.1.5 Prepurging time

225 Gas: Prepurging time

20 s – 60 min

8.4.1.6 Postpurge time

234 Gas: Postpurge time (no external light test)

0,2 s – 108 min

8.4.1.7 Postpurging in lockout position

190 Postpurging in lockout position

0 = deactivate (no-load position)

1 = active (postpurge position)

(Factory settings marked with bold text).

When active, the Alarm in the event of start prevention function (parameter 210) is only possible to a limited extent!

8.4.1.8 Continuous fan

A burner can be converted into a continuous fan using conversion kit 119 230 01. See the documentation provided with the kit for instructions on how to perform the conversion.

8.4.1.9 Continuous operation

The LMV37 automatic control unit permits continuous operation of the burner, provided that the burner's detector flame is an ionisation detector flame.

When forced intermittent operation is activated, the unit shuts down for a moment after 23 hours and 45 min of uninterrupted operation, followed by an automatic restart.

When forced intermittent operation is inactivated the burner will run continuously.

Forced intermittent operation is a standard feature.

239 Gas: Forced intermittent operation

0 = inactivate

1 = activated

(Factory settings marked with bold text).



When the Purging in the lockout position function is used, the fan may only be powered via a contactor and must not be connected directly to LMV37.4 (X3-05 pin 1)!

8.4.2 Adjusting settings of previously set automatic control unit



With the warm settings, the burner is started up after pressing the Info  button . Air-fuel ratio control can now be accurately set while the flame is present on the respective component on the burner, see chapter "Burner settings".

- Check that the burner is connected to gas and has gas pressure.
- Check that the burner is connected to an electrical supply.
- Turn the switch (X) to ON position, the display (Z) will be active.
- Turn the switch (Y) to ON position.
- Follow the description below to set the burner.

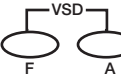
Press  > 1 second to access login mode.

- To continue with the settings, you need to log into service engineer level, see X.3.4 Access code for service engineer level.
- After login is complete, continue with the setting work as shown below.

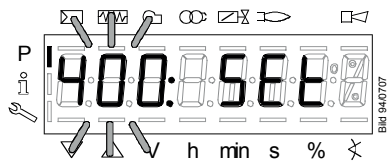
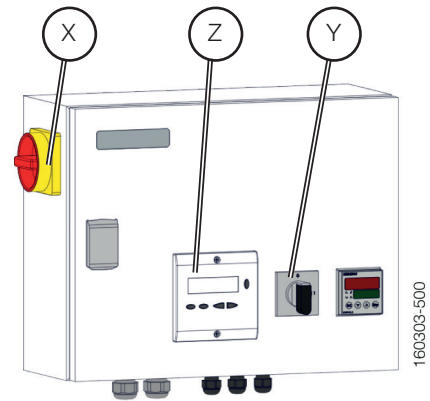

Press  to select parameter **400** for initial commissioning.

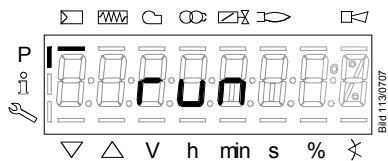

Identification of start for setting the curve parameters.



If, during the time the curve is parameterized, an error occurs which leads to safety shutdown, parameterization of the curve is quit.

The startup process on the automatic control unit now takes place. To see what happens in each phase, go to chapter X.3 Phase numbers. When the automatic control unit has completed the start procedure and the burner has started, step to **P9**.

Press  when P9 flashes.

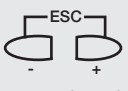

If  is pressed before **P9** flashes, the burner is turned off and the automatic control unit enters **OFF UPr** mode.

The maximum capacity is displayed.

If the display shows - - - -, the maximum capacity has not yet been specified. The system can be run up to 100%.

You can press  to go to editing mode, enabling you to change the

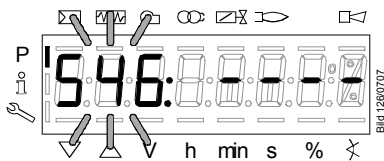

maximum capacity.

Adjust the setting downwards or upwards using the buttons .

Press  to save the setting.

Press  to return to parameter level.



To the next parameter.

The minimum capacity is displayed.

If the display shows - - - -, the minimum capacity has not yet been entered.

The system can be run down to 20%.

You can press  to go to editing mode,

enabling you to change the minimum capacity.

Adjust the setting downwards or upwards using the buttons 

Press  to save the setting.

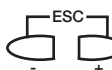
Press  to return to parameter level.

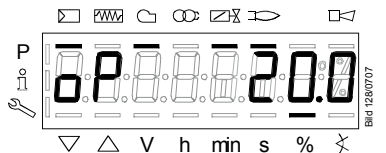
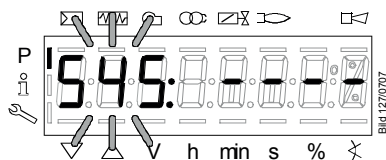

The warm settings for LMV37... are now completed.

8.5 Backup and restore



When adjustments to the burner are complete, it is a good idea to make a backup of the settings.

The backup ensures that the adjusted values are also saved in the display memory. This can be useful, e.g. if there are any problems with the LMV. The LMV can then be replaced and previous settings for the burner restored from the display memory to the new LMV.



Backup: Means that the parameters set on the LMV control unit are saved in the display memory.

Restore: Means that the settings saved in the display memory are transferred to the LMV and these overwrite any settings already in the LMV. The transferred parameter settings then act as operating parameters for the burner.

8.5.1 Backup

Press   > 1 second to access login mode.

To continue with the setting work, you need to log into service engineer level. See 5.3.4. After login is complete, continue with the setting work as shown below.

Press  or  for parameter level **000**.

Press  **reset**

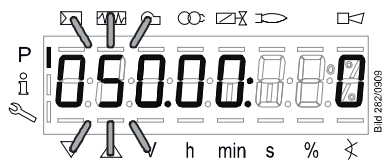

Display: Parameter **050**, flashes, index **00**, and value **0** do not.

 **reset**



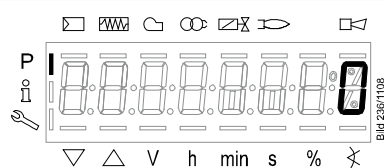

Display: Parameter **bAC_UP**

 **reset**



Display: Value **0**

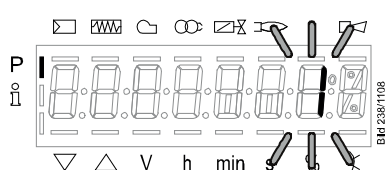

Press  to backup process.

Press  to shift the value in change mode 1 position to the left.



Display: Value **1** flashes

 To detect potential display errors, the value is displayed 1 place shifted to the left

 Note! The value must be set to 1 if a backup is required, and to 0 if a backup is not required.
 The values higher than 1 which can be set must not be used.

Press  to activate the backup process.

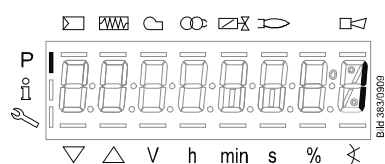

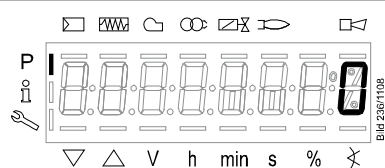

Display: **1** appears





After about 5 seconds (depending on the duration of the program), **0** appears on the display, indicating the end of the backup process.

Display: **0**

 If an error occurs during the backup process, a negativ value is displayed. For error diagnostics, the cause of the error can be determined from the diagnostic code of error message 137 (see Error code list)



Press  four times until the top menu is displayed.

8.5.2 Restore

Press   > 1 second to access login mode.

To continue with the setting work, you need to log into service engineer level, see X.3.4 Access code for service engineer level.

After login is complete, continue with the setting work as shown below.

Press  or  for parameter level **000**.

Press  **reset**

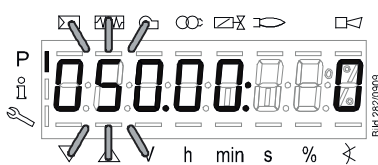

Display: Parameter **050**, flashes, index **00**, and value **0** do not.

 **reset**

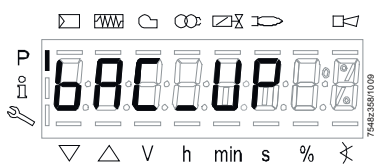

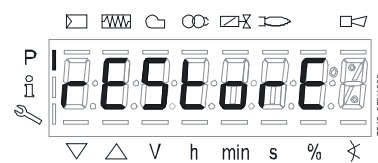

Display: Parameter **bAC_UP**

Press  to select parameter **rESstorE**



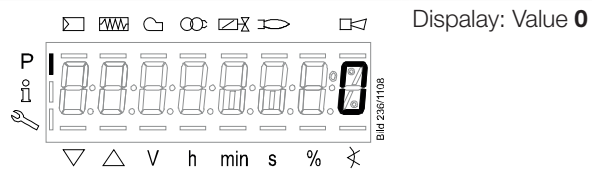

 **reset**

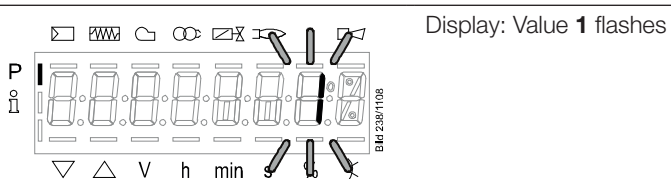

Press  to select the restore process.

Press  to shift the value in change mode 1 position to the left.



 To detect potential display errors, the value is displayed 1 place shifted to the left

Press  to activate the the restore process.

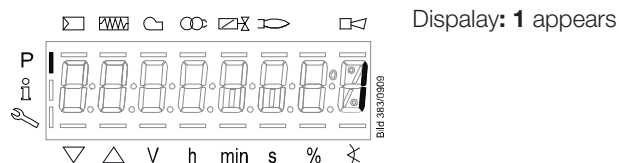

Display: **1** appears

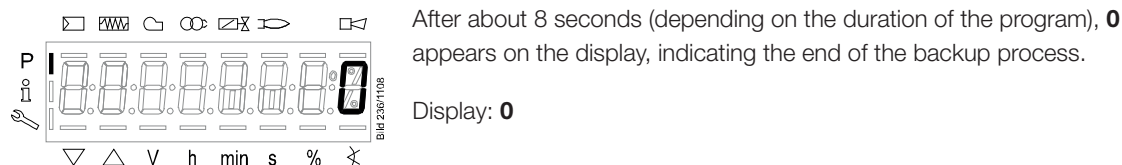

After about 8 seconds (depending on the duration of the program), **0** appears on the display, indicating the end of the backup process.

Display: **0**

Press  four times until the top menu is displayed.

8.6 Fault status message, display of errors and info

8.6.1 Display of errors (faults) with lockout

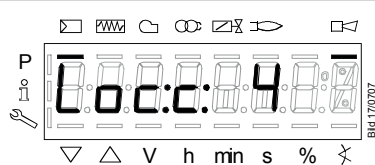

The display shows Loc., the bar under the fault status message  appears.

The unit is in the lockout position.





The display shows current error code c: alternating with diagnostic code d: (refer to Flash code list).

Example: Error code 4/diagnostic code 3

When pressing  for 1...3 s, **rESEt** appears on the display.

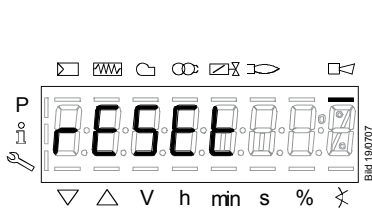
When the button is released, the basic unit is reset.



If the  button is pressed for a time other than the time indicated above, a change to the previous menu is made.

Exception
If an error occurred while setting the curve, a change back to the parameter setting level is made.

8.6.2 Activating info / service mode from lockout

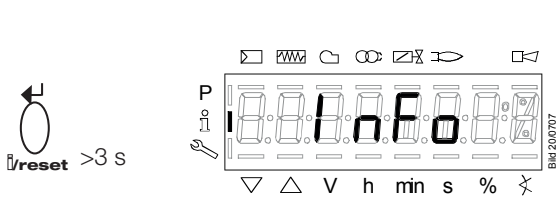

When pressing  for >3 s, the display shows Info,

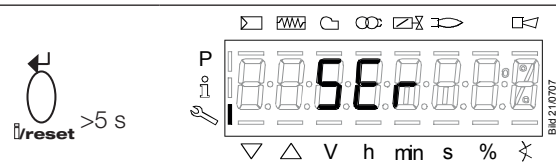

SEr and then **OPErAtE**.

For a list of parameters, see table 5.3.3.

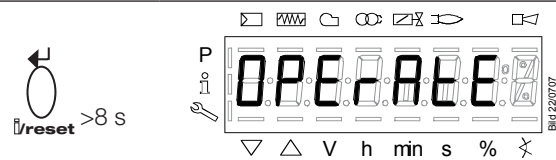

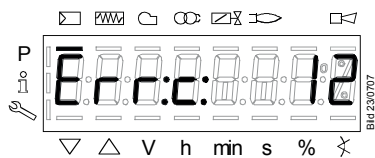

When the button is released, a change to info / service mode is made.

8.6.3 Error with safety shutdown

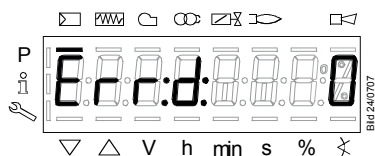

The display shows **Err:**
The unit initiates safety shutdown.
The display shows current error code c:
alternating with diagnostic code d:.





Press  1...3 second, to return to the normal display.

Example: Error code **12** / diagnostic code **0**

8.6.4 Error history

Press   > 1 second to access login mode.

To continue with the setting work, you need to log into service engineer level. See 5.3.4.
After login is complete, continue with the setting work as shown below.

Press  or  for parameter level **700**.

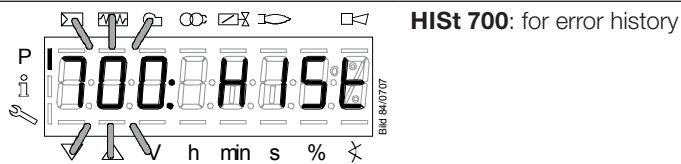

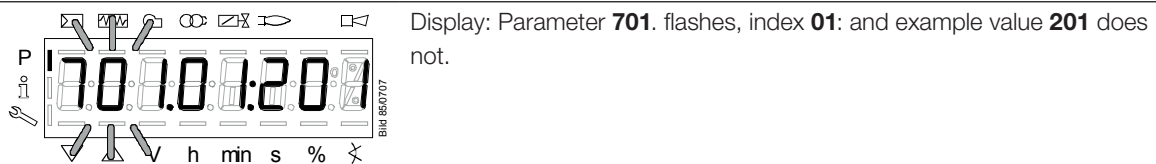

Press  to go to the parameter level.

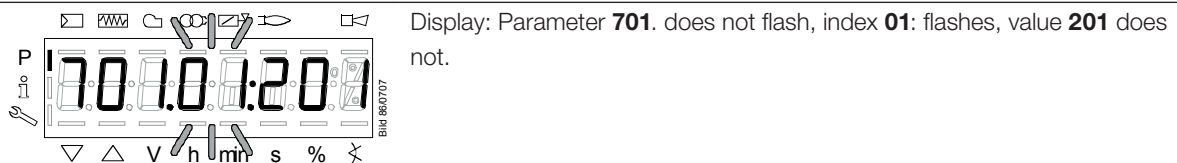

Press  1...3 second to go to index **01**:



To the next index  Back to the previous index. 

Press  to select the index:

- .01 = error code
- .02 = diagnostic code
- .03 = error class
- .04 = error phase
- .05 = startup counter
- .06 = output

Example:

Parameter **701.**, index **05**: for startup counter, diagnostic code **._._**

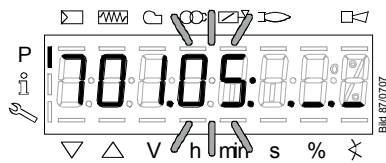

Press  **reset** 1...3 second.

Press  to go to display mode.

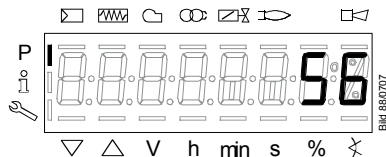

Display: Value **56** (number of startup)



Press  to return to the index.

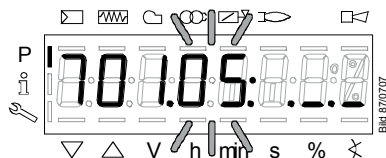

Display: Parameter **701.** does not flash, index **05**: flashes, characters **._._** do not.



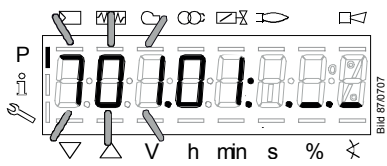

Press to return to the parameter level.

Display: Parameter **701**. flashes index **01**: does not, characters **.__** do not.

To the next old error

Shows all saved error codes between 701 and 725.

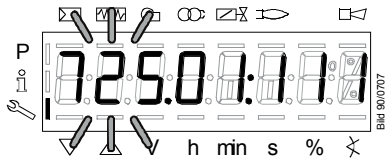

Parameters cover the period of time back to the last error since history was deleted (max. to parameter **725**.)

Example:

Parameter **725**., index **01**., error code **111**

To the next parameter Back to the previous parameter.

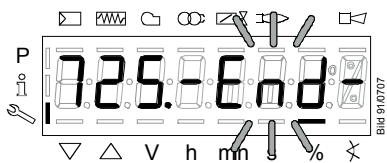

When this display appears, you have reached the end of the error history index.

Display – **End** – appears flashing.

To the next index Back to the previous index.

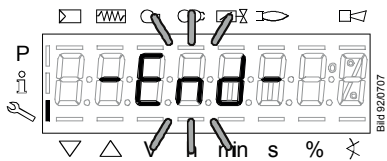

When this display appears, you have reached the end of the error history.

Display – **End** – appears flashing.

Press twice.

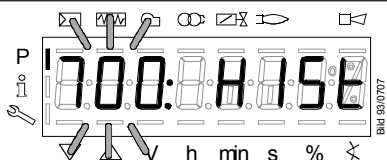

HISt 700: for error history

8.7 Display message of info

8.7.1 General information

The unit displays an event which does not lead to shutdown.

The display shows current error code c: alternating with diagnostic code d:.

Press to return to the display of phases.

Example: Error code **111** / diagnostic code **0**

Note
 For meaning of the error and diagnostic codes, refer to chapter Error code list. When an error has been acknowledged, it can still be read out from the error history.

8.7.2 Start prevention

A non-programmed or not completely parameterized unit, or a unit whose operating mode was reset or changed, displays **OFF UPr**.

8.7.3 Safety loop

A unit whose safety loop and / or burner flange contact is open, and a controller ON signal is present, displays **OFF S**.

8.8 Resetting the automatic control unit

Press  > 1 second to access login mode.

To continue with the setting work, you need to log into service engineer level. See 5.3.4.

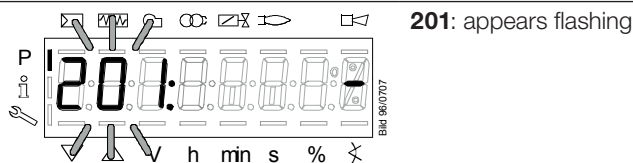

After login is complete, move to parameter level **200** using  or .

Press  **reset**

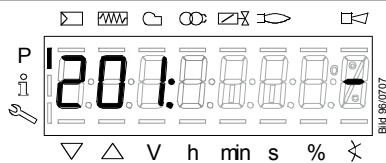

Press  **reset** to go to the settings for air-fuel ratio control and parameter **201** for selecting the operating mode.



Select another burner type than the one already selected by pressing one of the buttons  or .

Confirm this selection with  **reset**. The automatic control unit is now reset.

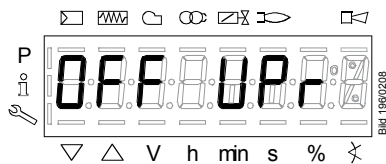

Restart the setting process for the LMV automatic control unit as specified in 3.2.1.

8.9 Manual output

A manual output can be set with the «Normal display» of the display and operating unit.

8.9.1 Activation of Manually OFF in standby via the display and operating unit

When the burner is in OFF position it can be set to Manually OFF which means that the burner will not start.

Manual OFF can be activated by pressing  for at least 1 second then **LoAd 0.0** appears flashing.

LoAd 0.0 means Manually OFF.

As long as the Manual OFF is active, **OFF** appears on the normal display flashing.



To deactivate and to change to automatic operation, press  for 3 seconds. Then OFF appears without flashing in the display.

8.9.2 Activation of Manually OFF in operation and adjustment of output via the display and operating unit

When the burner is in operation position it can be set to Manually OFF which means that the load of the burner can be manually set and will not start if the burner is shut down.

To activate Manually OFF, first run the system to the minimum output limit.

Manual OFF can be activated by pressing  for at least 1 second then **LoAd 0.0** appears flashing.

Adjustment of **LoAd** can now manually be done by pressing  and simultaneous pressing  or .

The burner will now stay in set input if none of the safety regulators stops the burner.

To deactivate and to change to automatic operation, press  for 3 seconds.



If Manually OFF is activated, it is stored via mains OFF.
On power return, the burner assumes the Manually OFF position (OFF flashing).



Please note that the automatic control unit will not exit manual mode by itself.
Make sure that the automatic control unit is reset to automatic mode.



The unit can be changed to manual mode without login taking place. If the automatic control unit has been left in manual mode, no automatic burner control will take place, which in turn means that the installation is not operating satisfactorily. For this reason, make sure when servicing/troubleshooting that the automatic control unit is not in manual mode.



Manually OFF must not be used just to put a burner out of operation when doing mounting work, or
when the burner is not ready for operation. The safety notes contained in chapter Safety notes must be observed!

9. Parameter list

Par. no.	Parameter	Number of elements	Type	Edit	Value range Min	Value range Max	Resolution	Default setting	Password level
000	Internal parameters								
050	Start backup / restore via AZL2.../ PC software (set parameter to 1) Index 0: Create backup Index 1: Execute restore Error diagnostics via negative values (see error code 137)	2	Std_s8	edit	-99	50	1	0; 0	SO
055	Burner identification of AZL2... backup data set	1	Std_s32	read only	0	99999999	1	0	SO
056	ASN extraction of AZL2... backup data set	8	Std_u8	read only	0	127	1	0	SO
057	Software version when creating the AZL2... backup data set	1	Hex_16	read only	0x100	0xFFFF9	1	0	SO
100	General								
102	Identification date	1	Date	read only	0	255	1		Info / Service
103	Identification number	1	Std_u16	read only	0	65535	1		Info / Service
104	Preselected parameter set: Customer code	1	Std_u8	read only	0	255	1	9	Info / Service
105	Preselected parameter set: Version	1	Hex_16	read only	0	0xFFFF	1	LMV37.400.... V 01.05 LMV37.420.... V 01.06	Info / Service
107	Software version	1	Hex_16	read only	0x100	0xFFFF9	1	V 03.30	Info / Service
108	Software variant	1	Std_u8	read only	0	255	1	LMV37.400.... 1 LMV37.420.... 2	Info / Service
111	ASN extraction for verification with the AZL2... backup data set	8	Std_u8	read only	0	127	1	0	SO
113	Burner identification	1	Std_s32	edit	0	99999999	1	undefined	SO
121	Manual output Undefined = automatic mode	1	Output	edit / clear	0%	100%	0.1%	undefined	Info / Service
123	Minimum output positioning step Index 0: BACS output Index 1: Output of external load controller, analog Index 2: Output of external load controller contacts	3	Output	edit	0%	100%	0.1%	Index 0 1 2 Value 0% 1% 0%	SO
124	Start loss-of-flame test (TÜV test) (set parameter to 1) (shutdown of fuel valves → loss of flame) Error diagnostics via negative values (see error code 150)	1	Std_s8	edit	-6	1	1	0	SO
125	Mains frequency 0 = 50 Hz 1 = 60 Hz	1	Selection	edit	0	1	1	LMV37.400....: 0 LMV37.420....: 1	SO

Par. no.	Parameter	Number of elements	Type	Edit	Value range Min Max	Resolution	Default setting	Password level
126	Display brightness	1	Std_u8	edit	0% 100%	1%	LMV37.400...: 75 % LMV37.420...: 100 %	SO
128	Fuel meter: Pulse valency [pulses / volume unit]	1	Std_u16	edit	0 400	0.01	0	SO
130	Delete display of error history To delete the display: Set parameter to 1, then to 2 Return value 0: Job successfully completed Return value -1: Timeout of 1_2 sequence	1	Std_s8	edit	-5 2	1	0	SO
133	Default output for TÜV test Invalid = TÜV test when output is active 2.000...10.000 = low-fire...high-fire or stage 1 / stage 2 / stage 3	1	Output	edit / clear	20 % 100 %	0.1 %	undefined	SO
141	Operating mode BACS 0 = off 1 = Modbus 2 = reserved	1	Selection	edit	0 2	1	0	SO
142	Setback time in the event of communication breakdown Setting values 0 = inactive 1...7200 s	1	Std_u16	edit	0 s 7200 s	1 s	120 s	SO (BA)
143	Reserved	1	Std_u8	edit	1	1	1	Info / Service
144	Reserved	1	Std_u16	edit	10 s 60 s	1 s	30 s	SO
145	Device address for Modbus of basic unit Setting values 1...247	1	Std_u8	edit	1 247	1	1	SO
146	Setting of Baud rate for Modbus communication Setting values 0 = 9600 1 = 19200	1	Selection	edit	0 1	1	1	SO
147	Parity for Modbus 0 = none 1 = odd 2 = even	1	Selection	edit	0 2	1	0	SO

Par. no.	Parameter	Number of elements	Type	Edit	Value range Min	Value range Max	Resolution	Default setting	Password level
148	Default output if communication with building automation is interrupted Setting values: For modulation operation the setting range is as follows: 0...19.9 = burner off 20...100 = 20...100% burner rating For multistage operation apply to setting range: 0 = burner OFF, P1, P2, P3 Invalid = no default output predefined by building automation Default setting: Invalid	1	Output	edit / clear	0%	100%	0.1%	undefined	SO (BA)
161	Number of faults	1	Std_u16	read only	0	65535	1	0	Info / Service
162	Operating hours resettable	1	Std_s32	reset	0 h	9999999 h	1 h	0 h	Info / Service
163	Operating hours when unit is live	1	Std_s32	read only	0 h	9999999 h	1 h	0 h	Info / Service
164	Number of startups resettable	1	Std_s32	reset	0	9999999	1	0	Info / Service
166	Total number of startups	1	Std_s32	read only	0	9999999	1	0	Info / Service
167	Fuel volume resettable [m ³ , l, ft ³ , gal]	1	Std_s32	reset	0	999999999	1	0	Info / Service
176	Switching back to pilot switching cycles	1	Std_s32	read only	0	99999999	1	0	Info / Service
190	Postpurging in lockout position 0 = deactivate (no-load position) 1 = active (postpurge position) When active, the Alarm in the event of start prevention function is only possible to a limited extent!	1	Selection	edit	0	1	1	0	SO
191	Function Switching back to pilot 0 = deactivate 1 = active (low active) 2 = active (high active) Load controller contacts X5-03 are deactivated when function is active!	1	Std_u8	edit	0	2	1	0	SO
192	Switching back to pilot minimum time	1	Time	edit	5 s	120 s	0,2 s	30 s	SO
193	Switching back to pilot maximum time	1	Time	edit	30 s	108 min.	0,2 s	60 min.	SO
195	Repetition limit heavy oil direct start 1 = no repetition 2...15 = 1...14 number of repetitions 16 = constant repetition	1	Std_u8	edit	1	16	1	3	SO

Par. no.	Parameter	Number of elements	Type	Edit	Value range Min	Value range Max	Resolution	Default setting	Password level
200	Basic unit								
201	Burner operating mode (fuel train, modulating / multistage, actuators, etc.) -- = undefined (delete curves) 1 = G mod 2 = Gp1 mod 3 = Gp2 mod 4 = Lo mod 5 = Lo 2-stage 6 = Lo 3-stage 7 = G mod pneu 8 = Gp1 mod pneu 9 = Gp2 mod pneu 10 = LoGp mod 11 = LoGp 2-stage 12 = Lo mod 2 fuel valves 13 = LoGp mod 2 fuel valves 14 = G mod pneu without actuator 15 = Gp1 mod pneu without actuator 16 = Gp2 mod pneu without actuator 17 = Lo 2-stage without actuator 18 = Lo 3-stage without actuator 19 = G mod only gas actuator 20 = Gp1 mod only gas actuator 21 = Gp2 mod only gas actuator 22 = Lo mod only oil actuator 23 = Ho mod. sep. circulation 24 = Ho 2-stage sep. circulation 25 = Ho mod. without circulation 26 = Ho 2-stage without circulation 27 = Ho 3-stage without circulation	1	Selection	edit / clear	1	27	1	undefined	SO
204	Analog output invalid (4...20 mA) 0 = default load low-fire 1 = safety shutdown + start prevention	1	Std_u8	edit	0	1	1	1	SO
208	Program stop 0 = inactive 1 = PrePurgP (Ph24) 2 = IgnitPos (Ph36) 3 = interval 1 (Ph44) 4 = interval 2 (Ph52)	1	Selection	edit	0	4	1	0	SO (BA)
210	Alarm in the event of start prevention 0 = deactivated 1 = activated	1	Selection	edit	0	1	1	LMV37.400...: 0 LMV37.420...: 1	SO

Par. no.	Parameter	Number of elements	Type	Edit	Value range Min	Value range Max	Resolution	Default setting	Password level
211	Fan ramp up time	1	Time	edit	2 s	60 s	0.2 s	2 s	SO
212	Max. time down to low-fire	1	Time	edit	0.2 s	10 min	0.2 s	45 s	SO
215	Repetition limit safety loop 1 = no repetition 2...15 = 1...14 number of repetitions 16 = constant repetition	1	Std_u8	edit	1	16	1	LMV37.400...: 16 LMV37.420...: 1	SO
221	Gas: Active detector flame evaluation 0 = QRB / QRC 1 = ION / QRA	1	Selection	edit	0	1	1	1	SO
222	Gas: Prepurging 0 = deactivated 1 = activated	1	Selection	edit	0	1	1	1	SO
223	Repetition limit gas pressure switch-min 1 = no repetition 2...15 = 1...14 number of repetitions 16 = constant repetition	1	Std_u8	edit	1	16	1	LMV37.400...: 16 LMV37.420...: 1	SO
225	Gas: Prepurge time	1	Time	edit	LMV37. 400...: 20 s LMV37. 420...: 5 s	60 min	0.2 s	LMV37. 400...: 20 s LMV37. 420...: 30 s	SO
226	Gas: Preignition time	1	Time	edit	0.4 s	60 min	0.2 s	2 s	SO
230	Gas: Interval 1	1	Time	edit	0.4 s	60 s	0.2 s	2 s	SO
232	Gas: Interval 2	1	Time	edit	0.4 s	60 s	0.2 s	2 s	SO
233	Gas: Afterburn time	1	Time	edit	0.2 s	60 s	0.2 s	8 s	SO
234	Gas: Postpurge time (no extraneous light test)	1	Time	edit	0.2 s	108 min	0.2 s	LMV37.400...: 0,2 s LMV37.420...: 15 s	SO
235	Gas: Air pressure switch (LP) 0 = inactive 1 = active 2 = active, except phase 60...66 (pneumatic operation only)	1	Selection	edit	1	2	1	1	SO
236	Gas: Pressure switch-min input 0 = inactive 1 = pressure switch-min (upstream of fuel valve 1 (V1)) 2 = valve proving via pressure switch-min (between fuel valves 1 (V1) and 2 (V2))	1	Selection	edit	1	2	1	1	SO
237	Gas: Pressure switch-max / POC input 0 = inactive 1 = pressure switch-max 2 = POC 3 = pressure switch valve proving	1	Selection	edit	1	2	1	LMV37.400...: 1 LMV37.420...: 2	SO

Par. no.	Parameter	Number of elements	Type	Edit	Value range Min	Value range Max	Resolution	Default setting	Password level
239	Gas: Forced intermittent operation 0 = inactive 1 = activated	1	Selection	edit	0	1	1	1	SO
241	Gas: Execution valve proving 0 = no valve proving 1 = valve proving on startup 2 = valve proving on shutdown 3 = valve proving on startup and shutdown	1	Selection	edit	0	3	1	LMV37.400...: 2 LMV37.420...: 0	SO
248	Gas: Postpurge time (t3) (abortion with load controller (LR)-ON	1	Time	edit	1 s	108 min	0.2 s	1 s	SO
400	Ratio curves								
401	Ratio control curve fuel actuator (only curve settings)	13	Std_s16	edit	0°	90°	0.1°	0°; 0°; 15°; undefined	SO
402	Ratio control curve air actuator (only curve settings)	13	Std_s16	edit	0°	90°	0.1°	0°; 90°; 45°; undefined	SO
403	Ratio control curve VSD (only curve settings)	13	Std_s16	edit	15 %	100%	0.1%	0%; 100%; 50%; undefined	SO
500	Ratio control								
501	No-flame positions fuel actuator Index 0 = home position Index 1 = prepurge position Index 2 = postpurge position	3	Std_s16	edit	0°	90°	0.1°	Index Value 0 0° 1 0° 2 15°	SO
502	No-flame positions air actuator Index 0 = home position Index 1 = prepurge position Index 2 = postpurge position	3	Std_s16	edit	0°	90°	0.1°	Index Value 0 0° 1 90° 2 45°	SO
503	No-flame speeds VSD Index 0 = no-load speed Index 1 = prepurge speed Index 2 = postpurge speed	3	Std_s16	edit	0%	100%	0.1%	Index Value 0 0% 1 100% 2 50%	SO
522	Ramp up	1	Std_u8	edit	5 s	40 s	1 s	10 s	SO
523	Ramp down	1	Std_u8	edit	5 s	40 s	1 s	10 s	SO
542	Activation of VSD / PWM fan 0 = inactive 1 = active	1	Selection	edit	0	1	1	0	SO
544	Ramp modulating	1	Std_u8	edit	32 s	80 s	1 s	32 s	SO
545	Lower output limit undefined = 20 %	1	Output	edit / clear	20%	100%	0.1%	undefined	SO (BA)

Par. no.	Parameter	Number of elements	Type	Edit	Value range Min	Value range Max	Resolution	Default setting	Password level
546	Upper output limit undefined = 100 %	1	Output	edit / clear	20%	100%	0.1%	undefined	SO (BA)
600	Actuators								
601	Selection of reference point Index 0 = fuel Index 1 = air 0 = close (<0°) 1 = open (>90°)	2	Selection	edit	0	1	1	Index 0 1 Value 0 1	SO
602	Actuator's direction of rotation Index 0 = fuel Index 1 = air 0 = counterclockwise 1 = clockwise (exclusively for SQM3...)	2	Selection	edit	0	1	1	Index 0 1 Value 0 1	SO
606	Tolerance limit of position monitoring [0.1°] Index 0 = fuel Index 1 = air Greatest position error where a fault is securely detected → error detection band: (parameter 606-0.6°) to parameter 606	2	Std_u8	edit	0.5°	4°	0.1°	Index 0 1 Value 1.7° 1.7°	SO
611	Type of referencing Index 0 = fuel Index 1 = air 0 = standard 1 = stop within usable range 2 = internal stop (SQN1...) 3 = both	2	Std_u8	edit	0	3	1	Index 0 1 Value 0 0	SO
613	Type of actuator Index 0 = fuel Index 1 = air 0 = 5 s / 90° (1 Nm, 1,2 Nm, 3 Nm) 1 = 10 s / 90° (6 Nm) 2 = 17 s / 90° (10 Nm)	2	Std_u8	edit	0	2	1	0; 0	SO
641	Control of speed standardization of VSD Error diagnostics of negative values (refer to error code 82) 0 = no speed standardization 1 = speed standardization active	1	Std_s8	edit	-25	1	1	0	SO
642	Standardized speed Index 0 = speed 1 Index 1 = speed 2 (internal supervision)	2	Std_u16	read only	650	6500	0.1	undefined	SO

Par. no.	Parameter	Number of elements	Type	Edit	Value range Min	Value range Max	Resolution	Default setting	Password level
645	Configuration of analog output 0 = DC 0...10 V 1 = DC 2...10 V 2 = DC 0/2...10 V	1	Std_u8	edit	0	2	1	0	SO
652	VSD behavior when safety loop / burner flange is open 0 = no VSD control when safety loop / burner flange is open 1 = VSD control independent of safety loop / burner flange	1	Std_u8	edit	0	1	1	1	HF
653	VSD standstill supervision in standby mode 0 = deactivate 1 = active	1	Std_u8	edit	0	1	1	1	HF
700	Error history								
701	Error history: 701-725.01.Code	25	Std_u8	read only	0	255	1	0	Info / Service
•	Error history: 701-725.02.Diagnostic code	25	Std_u8	read only	0	255	1	0	Info / Service
•	Error history: 701-725.03.Error class	25	Std_u8	read only	0	6	1	0	Info / Service
•	Error history: 701-725.04.Phase	25	Std_u8	read only	0	255	1	0	Info / Service
•	Error history: 701-725.05.Startup counter	25	Std_s32	read only	0	99999999	1	0	Info / Service
725	Error history: 701-725.06.Output	25	Output	read only	0%	100 %	0.1%	0%	Info / Service
900	Process data								
903	Current output Index 0 = fuel Index 1 = air	2	Output	read only	0%	100%	0.1%	0%	Info / Service
922	Incremental position of actuators Index 0 = fuel Index 1 = air	2	Std_s16	read only	-50°	150°	0.01°	0°	Info / Service
935	Absolute speed	1	Std_u16	read only	0	6553.5	0.1	0	SO
936	Standardized speed	1	Std_s16	read only	-200%	200%	0.1%	0%	Info / Service
942	Active load source 1 = output during curve settings 2 = manual output 3 = default output via building automation 4 = default output via analog input 5 = external load controller via contacts	1	Selection	read only	0	255	1	0	SO

Par. no.	Parameter	Number of elements	Type	Edit	Value range Min	Value range Max	Resolution	Default setting	Password level
947	Result of contact sensing (bit-coded) Bit 0.0 = 1: Pressure switch-min Bit 0.1 = 2: Pressure switch-max Bit 0.2 = 4: Pressure switch valve proving Bit 0.3 = 8: Pressure switch air pressure switch Bit 0.4 = 16: Load controller OPEN Bit 0.5 = 32: Load controller ON Bit 0.6 = 64: Load controller CLOSE Bit 0.7 = 128: Safety loop Bit 1.0 = 1: Safety valve Bit 1.1 = 2: Ignition Bit 1.2 = 4: Fuel valve 1 Bit 1.3 = 8: Fuel valve 2 Bit 1.4 = 16: Fuel valve 3 / pilot valve Bit 1.5 = 32: Reset	2	Std_u8	read only	0	255	1	0	Info / Service
948	Contact feedback network counter register	14	Std_u8	read only	0	255	1	0	SO
950	Required relay state (bit-coded) Bit 0 = 1: Alarm Bit 1 = 2: Safety valve Bit 2 = 4: Ignition Bit 3 = 8: Fuel valve 1 Bit 4 = 16: Fuel valve 2 Bit 5 = 32: Fuel valve 3 / pilot valve	1	Std_u8	read only	0	255	1	0	Info / Service
951	Mains voltage (normalized) AC 230 V: Voltage = value x 1.683 AC 120 V: Voltage = value x 0.843	1	Std_u8	read only	0 V	255 V	1 V	0 V	SO
954	Intensity of flame	1	Std_u8	read only	0%	100%	1%	0%	Info / Service
960	Actual flow rate (m³/h, l/h, ft³/h, gal/h)	1	Std_u16	read only	0	6553.5	0.1	0	Info / Service
961	Phase (state for external modules and display)	1	Std_u8	read only	0	255	1	0	Info / Service
981	Error memory: Code	1	Std_u8	read only	0	255	1	0	Info / Service
982	Error memory: Diagnostic code	1	Std_u8	read only	0	255	1	0	Info / Service
992	Error flags	10	Hex_32	reset	0	0xFFFFFFFF	1	0	SO

Std_u8 8 bit integer, **not** signed

Std_u16 16 bit integer, **not** signed

Std_u32 32 bit integer, **not** signed

Std_s8 8 bit integer, signed

Std_s16 16 Bit integer, signed

Std_s32 32 Bit integer, signed

Note

This data type is also used to mark an invalid or non-signed value by using the value of -1!

10. Error code list

Error code	Diagnostic code	Meaning for the LMV37.4... system	Remedy
no Comm		No communication between LMV37.4... basic unit and AZL2...	Check wiring for line interruption/loose contact
2	#	No flame at the end of the safety time (TSA)	
	1	No flame at the end of safety time 1 (TSA1)	
	2	No flame at the end of safety time 2 (TSA2)	
	4	No flame at the end of safety time 1 (TSA1) (software version ≤ V02.00)	
3	#	Air pressure failure	
	0	Air pressure off	
	1	Air pressure on	
	2	Evaluation of air pressure	Correct the setting of parameter 235 or 335 (Deactivation of the air pressure check in operation only allowed in pneumatic operation!)
	4	Air pressure on – start prevention	
	20	Air pressure, combustion pressure – start prevention	
	68	Air pressure, POC – start prevention	
	84	Air pressure, combustion pressure, POC – start prevention	
4	#	Extraneous light	
	0	Extraneous light during startup	
	1	Extraneous light during shutdown	
	2	Extraneous light during startup – start prevention	
	6	Extraneous light during startup, air pressure – start prevention	
	18	Extraneous light during startup, combustion pressure – start prevention	
	24	Extraneous light during startup, air pressure, combustion pressure – start prevention	
	66	Extraneous light during startup, POC – start prevention	
	70	Extraneous light during startup, air pressure, POC – start prevention	
	82	Extraneous light during startup, combustion pressure, POC – start prevention	
	86	Extraneous light during startup, air pressure, combustion pressure, POC – start prevention	
7	#	Loss of flame	
	0	Loss of flame	
	3	Loss of flame (software version ≤ V02.00)	
	3...255	Loss of flame due to TÜV test (loss-of-flame test)	

Error code	Diagnostic code	Meaning for the LMV37.4... system	Remedy
12	#	Valve proving	
	0	Fuel valve 1 (V1) leaking (fuel valve 2 with valve proving via X5-01)	For valve proving via X5-01 (gas pressure switch-min) - Check to see if the valve on the burner side is leaking - Check to see if the pressure switch for the valve proving is closed when gas pressure is present - Check wiring to see if there is a short-circuit
	1	Fuel valve 2 (V2) leaking (fuel valve 1 with valve proving via X5-01)	For valve proving via X5-01 (gas pressure switch-min) - Check to see if the valve on the gas side is leaking - Check wiring to see if there is a short-circuit
	2	Valve proving not possible	Valve proving activated, but pressure switch-min selected as input function for X9-04 (check parameters 238 and 241)
	3	Valve proving not possible	Valve proving activated, but no input assigned (check parameters 236 and 237)
	4	Valve proving not possible	Valve proving activated, but 2 inputs assigned (set parameter 237 to pressure switch-max or POC)
	5	Valve proving not possible	Valve proving activated, but 2 inputs assigned (check parameters 236 and 237)
	81	V1 leaking	Check to see if the valve on the gas side is leaking Check wiring to see if there is an open-circuit
	83	V2 leaking	Check to see if the valve on the burner side is leaking Check to see if the pressure switch for the leakage test is closed when gas pressure is present Check wiring for short-circuit
14	#	POC	
	0	POC open	Check to see if the valve's closing contact is closed
	1	POC close	Check wiring Check to see if the valve's closing contact opens when valve is controlled
	64	POC open – prevention of startup	Check wiring to see if there is a line interruption. Check to see if the valve's closing contact is closed
19	80	Combustion pressure, POC – start prevention	Check to see if pressure switch has closed with no combustion pressure present Check wiring for short-circuit
20	#	Pressure switch-min (Pmin)	
	0	No minimum gas /oil pressure	Check wiring for line interruption
	1	Gas shortage – start prevention	Check wiring for line interruption
21	#	Pressure switch-max (Pmax) / POC	
	0	Pressure switch-max (Pmax): Max. gas / oil pressure exceeded POC: POC open (software version ≤ V02.00)	Check wiring to see if there is a line interruption. POC: Check to see if the valve's closing contact is closed.
	1	POC close (software version ≤ V02.00)	Check wiring. Check to see if the valve's closing contact opens when the valve is controlled
	64	POC open – start prevention (software version ≤ V02.00)	Check wiring. Check whether valve's make contact opens when valve is controlled

Error code	Diagnostic code	Meaning for the LMV37.4... system	Remedy
22 OFF S	#	Safety loop / burner flange	
	0	Safety loop / burner flange open	
	1	Safety loop / burner flange open – start prevention	
	3	Safety loop/burner flange, extraneous light – start prevention	
	5	Safety loop/burner flange, air pressure – start prevention	
	17	Safety loop/burner flange, combustion pressure – start prevention	
	19	Safety loop/burner flange, extraneous light, combustion pressure – start prevention	
	21	Safety loop/burner flange, air pressure, combustion pressure – start prevention	
	23	Safety loop/burner flange, extraneous light, air pressure, combustion pressure – start prevention	
	65	Safety loop/burner flange, POC – start prevention	
	67	Safety loop/burner flange, extraneous light, POC – start prevention	
	69	Safety loop/burner flange, air pressure, POC – start prevention	
	71	Safety loop/burner flange, extraneous light, air pressure, POC – start prevention	
	81	Safety loop/burner flange, combustion pressure, POC – start prevention	
	83	Safety loop/burner flange, extraneous light, combustion pressure, POC – start prevention	
	85	Safety loop/burner flange, air pressure, combustion pressure, POC – start prevention	
	87	Safety loop/burner flange, extraneous light, air pressure, combustion pressure, POC – start prevention	
23	#	Gas pressure switch-min (Pmin) / heavy oil direct start	
	0	No minimum gas pressure	Check wiring to see if there is an open-circuit (X5-01)
	1	Gas shortage – start prevention	Check wiring to see if there is an open-circuit (X5-01)
	2	Heavy oil direct start	Check wiring to see if there is an open-circuit (X9-04) Check that the oil is preheated correctly
51	#	Internal error	Make a reset; if error occurs repeatedly, replace the unit
55	#	Internal error	Make a reset; if error occurs repeatedly, replace the unit
56	#	Internal error	Make a reset; if error occurs repeatedly, replace the unit
57	#	Internal error	Make a reset; if error occurs repeatedly, replace the unit
58	#	Internal error	Make a reset; if error occurs repeatedly, replace the unit
60	0	Internal error: No valid output source	Make a reset; if error occurs repeatedly, replace the unit
65	#	Internal error	Make a reset; if error occurs repeatedly, replace the unit
66	#	Internal error	Make a reset; if error occurs repeatedly, replace the unit

Error code	Diagnostic code	Meaning for the LMV37.4... system	Remedy
67	#	Internal error	Make a reset; if error occurs repeatedly, replace the unit
70	#	Error air-fuel ratio control: Position calculation modulating	
	23	Output invalid	No valid output
	26	Curvepoints undefined	Adjust the curvepoints for all actuators
71	#	Special position undefined	
	0	Home position	Parameterize the home position for all actuators used
	1	Prepurge position	Parameterize the prepurge position for all actuators used
	2	Postpurge position	Parameterize the postpurge position for all actuators used
	3	Ignition position	Parameterize the ignition position for all actuators used
72	#	Internal error air-fuel ratio control	Make a reset; if error occurs repeatedly, replace the unit
73	#	Internal error air-fuel control: Position calculation multistep	
	23	Output invalid	No valid output
	26	Curvepoints undefined	Adjust the curvepoints for all actuators
75	#	Internal error air-fuel ratio control: Data clocking check	
	1	Current output different	
	2	Target output different	
	4	Target positions different	
	16	Different positions reached	Can be caused by different standardized speeds (e.g. after restore of data set) when the VSD is activated → standardize again and check adjustment of the air-fuel ratio control system
76	#	Internal error air-fuel ratio control	Make a reset; if error occurs repeatedly, replace the unit
80	#	Control range limitation of VSD	Basic unit could not correct the difference in speed and reached a control range limit. 1. Basic unit is not standardized for this motor → repeat standardization. <div style="border: 1px solid black; padding: 5px; margin: 5px 0;"> <p style="text-align: center;">Caution! Settings of air-fuel ratio control must be checked!</p> </div> 2. Ramp time settings of the VSD are not shorter than those of the basic unit (parameters 522, 523) or the setting for the modulating operating ramp is incorrect (parameter 544) 3. Characteristic of the VSD is not linear. Configuration of the voltage input at the VSD must accord with that of the basic unit (parameter 645). 4. VSD does not follow quickly enough the changes of the basic unit. Check settings of the VSD (input filter, slippage compensation, hiding different speeds)

Error code	Diagnostic code	Meaning for the LMV37.4... system	Remedy
		Control range limitation at the bottom	VSD speed was too high
2		Control range limitation at the top	VSD speed was too low
81	1	Interrupt limitation speed input	Too much electromagnetic interference on the sensor line → improve EMC
82	#	Error during VSD's speed standardization	
1		Timeout of standardization (VSD ramp down time too long)	Timeout at the end of standardization during ramp down of the VSD → ramp time settings of the VSD are not shorter than those of the basic unit (parameter: 523)
2		Storage of standardized speed not successful	Error during storage of the standardized speed → lock the basic unit, then reset it and repeat the standardization
3		Line interruption speed sensor	Basic unit receives no pulses from the speed sensor: 1. Motor does not turn. 2. Speed sensor is not connected. 3. Speed sensor is not activated by the sensor disk (check distance)
4		Speed variation / VSD ramp up time too long / speed below minimum limit for standardization	Motor has not reached a stable speed after ramp up. 1. Ramp time settings of the VSD are not shorter than those of the basic unit (parameters 522, 523). 2. Characteristic of the VSD is not linear. Configuration of the voltage input at the VSD must accord with that of the basic unit (parameter 645). 3. VSD does not follow quickly enough the changes of the basic unit. Check settings of the VSD (input filter, slippage compensation, hiding different speeds) 4. Speed of VSD lies below the minimum for standardization (650 1/min)
5		Wrong direction of rotation	Motor's direction of rotation is wrong. 1. Motor turns indeed in the wrong direction → change parameterization of the direction of rotation or interchange 2 live conductors. 2. Sensor disk is fitted the wrong way → turn the sensor disk.
6		Unplausible speed sensor signals	The required pulse pattern (60°, 120°, 180°) has not been correctly identified. 1. Speed sensor does not detect all tappings of the sensor disk → check distance 2. As the motor turns, other metal parts are detected also, in addition to the tappings → improve mounting. 3. Electromagnetic interference on the sensor lines → check cable routing, improve EMC
7		Invalid standardized speed	The standardized speed measured does not lie in the permissible range → motor turns too slowly or too fast
15		Speed deviation $\mu C1 + \mu C2$	The speeds of microcomputer 1 and 2 deviated too much. This can be caused by wrong standardized speeds (e.g. after restoring a data set to a new unit) → repeat standardization and check the air-fuel ratio

Error code	Diagnostic code	Meaning for the LMV37.4... system	Remedy
20		Wrong phase of phase manager	Standardization was made in a wrong phase. Permitted are only phases ≤12 → controller OFF, start standardization again
21		Safety loop / burner flange open	Safety loop or burner flange is open → repeat standardization with safety loop closed
22		Air actuator not referenced	Air actuator has not been referenced or has lost its referencing. 1. Check if the reference position can be approached. 2. Check if actuators have been mixed up. 3. If error only occurs after the start of standardization, the actuator might be overloaded and cannot reach its destination.
23		VSD deactivated	Standardization was started with VSD deactivated → activate the VSD and repeat standardization
24		No valid operating mode	Standardization was started without valid operating mode → activate valid operating mode and repeat standardization
25		Pneumatic air-fuel ratio control	Standardization was started with pneumatic air-fuel ratio control → standardization with pneumatic air-fuel ratio control not possible
128		Running command with no preceding standardization	VSD is controlled but not standardized → make standardization
255		No standardized speed available	Motor turns but is not standardized → make standardization
83		Speed error VSD	Required speed has not been reached
Bit 0 Valency 1		Lower control range limitation	Speed has not been reached because control range limitation has become active → for measures, refer to error code 80
Bit 1 Valency 2...3		Upper control range limitation	Speed has not been reached because control range limitation has become active → for measures, refer to error code 80
Bit 2 Valency 4...7		Interrupt shutdown due to electromagnetic interference	Speed has not been reached due to too much electromagnetic interference on the sensor line → for measures, refer to error code 81
Bit 3 Valency ≥ 8		Curve too steep in terms of ramp speed	Check speed differential between the curvepoints and the modulating operating ramp setting (parameter 544). 1. Modulating operating ramp 32 seconds Curve slope max. 10% for LMV37.4 ramp of 20 seconds (20% for 10 seconds or 40% for 5 seconds) 2. Modulating operating ramp 48 seconds Curve slope max. 10% for LMV37.4 ramp of 30 seconds (20% for 15 seconds or 30% for 10 seconds) 3. Modulating operating ramp 64 seconds
			Curve slope max. 10% for LMV37.4 ramp of 40 seconds (20% for 20 seconds or 40% for 10 seconds) → Between the ignition point (P0) and the low-fire point (P1), the speed change in modulating mode may be a maximum of 40%, independent of the LMV3... ramp. 2. The setting of the VSD ramp must be about 20% faster than the ramps in the basic unit (parameters 522, 523).

Error code	Diagnostic code	Meaning for the LMV37.4... system	Remedy
	Bit 4 Valency ≥ 16	Interruption of speed signal	No speed detected in spite of control. 1. Check if the motor turns. 2. Check if the speed sensor delivers a signal (LED / check distance from the sensor disk). 3. Check wiring of the VSD.
	Bit 5 Valency ≥ 32	Quick shutdown due to excessive speed deviation	Speed deviation was for about 1 s >10% outside the anticipated range. 1. Check ramp times of the LMV37.4... and VSD. 2. Check wiring of the VSD.
84	Curve slope actuators		
	Bit 0 Valency 1	VSD: Curve too steep in terms of ramp speed	Check speed differential between the curvepoints and the modulating operating ramp setting (parameter 544). 1. Modulating operating ramp 32 seconds Curve slope max. 10% for LMV37.4 ramp of 20 seconds (20% for 10 seconds or 40% for 5 seconds) 2. Modulating operating ramp 48 seconds Curve slope max. 10% for LMV37.4 ramp of 30 seconds (20% for 15 seconds or 30% for 10 seconds) 3. Modulating operating ramp 64 seconds Curve slope max. 10% for LMV37.4 ramp of 40 seconds (20% for 20 seconds or 40% for 10 seconds) → Between the ignition point (P0) and the low-fire point (P1), the speed change in modulating mode may be a maximum of 40%, independent of the LMV3... ramp. 2. Setting of the VSD ramp must be about 20% shorter than the ramps in the basic unit (parameters 522 and 523)
	Bit 1 Valency 2..3	Fuel actuator: Curve too steep in terms of ramp rate	Check position differential between the curvepoints and the modulating operating ramp setting (parameter 544). 1. Modulating operating ramp 32 seconds The slope of the curve may be a maximum position change of 31° (15° for SQM33.6 and 9° for SQM33.7) between 2 curve points in modulating mode. 2. Modulating operating ramp 64 seconds The slope of the curve may be a maximum position change of 62° (30° for SQM33.6 and 18° for SQM33.7) between 2 curve points in modulating mode.
	Bit 2 Valency 4..7	Air actuator: Curve too steep in terms of ramp rate	Check position differential between the curvepoints and the modulating operating ramp setting (parameter 544). 1. Modulating operating ramp 32 seconds The slope of the curve may be a maximum position change of 31° (15° for SQM33.6 and 9° for SQM33.7) between 2 curve points in modulating mode. 2. Modulating operating ramp 64 seconds The slope of the curve may be a maximum position change of 62° (30° for SQM33.6 and 18° for SQM33.7) between 2 curve points in modulating mode.

Error code	Diagnostic code	Meaning for the LMV37.4... system	Remedy
85	#	Referencing error ones actuators	
	0	Referencing error of fuel actuator	Referencing of fuel actuator not successful. Reference point could not be reached. 1. Check the setting of the actuator type (parameter 613.0 or 614) 2. Check to see if actuators have been mixed up 3. Check to see if actuator is locked or overloaded
	1	Referencing error of air actuator	Referencing of fuel actuator not successful Reference point could not be reached. 1. Check the setting of the actuator type (parameter 613.1) 2. Check to see if actuators have been mixed up 3. Check to see if actuator is locked or overloaded
	Bit 7 Valency ≥ 128	Referencing error due to parameter change	Parameterization of an actuator (e.g. the reference position) has been changed. To trigger new referencing, this error is set
86	#	Error fuel actuator	
	0	Position error	Target position could not be reached within the required tolerance band → check to see if actuator is locked or overloaded
	Bit 0 Valency 1	Line interruption	Line interruption detected at actuator's terminals → check wiring (voltage X54 across pin 5 or 6 and pin 2 >0.5 V)
	Bit 3 Valency ≥ 8	Curve too steep in terms of ramp rate	Check position differential between the curvepoints and the modulating operating ramp setting (parameter 544). 1. Modulating operating ramp 32 seconds The slope of the curve may be a maximum position change of 31° (15° for SQM33.6 and 9° for SQM33.7) between 2 curve points in modulating mode. 2. Modulating operating ramp 64 seconds The slope of the curve may be a maximum position change of 62° (30° for SQM33.6 and 18° for SQM33.7) between 2 curve points in modulating mode.
	Bit 4 Valency ≥ 16	Step deviation in comparison with last referencing	Actuator was overloaded or mechanically twisted. 1. Check the setting of the actuator type (parameter 613.0 or 614) 2. Check to see if the actuator is blocked somewhere along its working range. 3. Check to see if the torque is sufficient for the application.
87	#	Error air actuator	
	0	Position error	Target position could not be reached within the required tolerance band → check to see if actuator is locked or overloaded
	Bit 0 Valency 1	Line interruption	Line interruption detected at actuator's terminals → check wiring (voltage X53 across pin 5 or 6 and pin 2 >0.5 V)
	Bit 3 Valency ≥ 8	Curve too steep in terms of ramp rate	Check position differential between the curvepoints and the modulating operating ramp setting (parameter 544). 1. Modulating operating ramp 32 seconds The slope of the curve may be a maximum position change of 31° (15° for SQM33.6 and 9° for SQM33.7) between 2 curve points in modulating mode. 2. Modulating operating ramp 64 seconds The slope of the curve may be a maximum position change of 62° (30° for SQM33.6 and 18° for SQM33.7) between 2 curve points in modulating mode.

Error code	Diagnostic code	Meaning for the LMV37.4... system	Remedy
	Bit 4 Valency ≥ 16	Sectional deviation in comparison with last referencing	Actuator was overloaded or mechanically twisted. 1. Check the setting of the actuator type (parameter 613.1) 2. Check to see if the actuator is blocked somewhere along its working range. 3. Check to see if the torque is sufficient for the application
90	#	Internal error basic unit	
91	#	Internal error basic unit	
93	#	Error flame signal acquisition	
	3	Short-circuit of sensor	Short-circuit at QRB... 1. Check wiring. 2. Flame detector possibly fault
95	#	Error relay supervision	
	3 Ignition transformer 4 Fuel valve 1 5 Fuel valve 2 6 Fuel valve 3	External power supply active contact	Check wiring
96	#	Error relay supervision	
	3 Ignition transformer 4 Fuel valve 1 5 Fuel valve 2 6 Fuel valve 3	Relay contacts have welded	Test the contacts: 1. Unit connected to power: Fan output must be dead. 2. Disconnect power: Disconnect fan. No resistive connection between fan output and neutral conductor allowed. If one of the 2 tests fails, release the unit since contact have definitively welded and safety can no longer be ensured.
97	#	Error relay supervision	
	0	Safety relay contacts have welded or external power supply fed to safety relay	Test the contacts: 1. Unit connected to power: Fan output must be dead. 2. Disconnect power: Disconnect fan. No resistive connection between fan output and neutral conductor allowed. If one of the 2 tests fails, release the unit since contacts have definitively welded and safety can no longer be ensured.
98	#	Error relay supervision	
	2 Safety valve 3 Ignition transformer 4 Fuel valve 1 5 Fuel valve 2 6 Fuel valve 3	Relay does not pull in	Make a reset; if error occurs repeatedly, replace the unit
99	#	Internal error relay control	
	3	Internal error relay control	Make a reset; if error occurs repeatedly, replace the unit Make a reset. If error occurs repeatedly, replace the unit Software version V03.10: If error C:99 D:3 occurs during standardization of the VSD, deactivate temporarily function Alarm in case of start prevention (parameter 210 = 0, when using a release contact) or interrupt the controller-ON signal

Error code	Diagnostic code	Meaning for the LMV37.4... system	Remedy
100	#	Internal error relay control	Make a reset; if error occurs repeatedly, replace the unit
105	#	Internal error contact sampling	
	0 Pressure switch min 1 Pressure switch max / POC 2 Pressure switch valve proving 3 Air pressure 4 Load controller open 5 Load controller on / off 6 Load controller close 7 Safety loop / Burner flange 8 Safety valve 9 Ignition transformer 10 Fuel valve 1 11 Fuel valve 2 12 Fuel valve 3 13 Reset	Stuck-At failure	Can be caused by capacitive loads or supply of DC voltage to the mains voltage inputs. The diagnostic code indicates the input where the problem occurred
106	#	Internal error contact request	Make a reset; if error occurs repeatedly, replace the unit
107	#	Internal error contact request	Make a reset; if error occurs repeatedly, replace the unit
108	#	Internal error contact request	Make a reset; if error occurs repeatedly, replace the unit
110	#	Internal error voltage monitor test	Make a reset; if error occurs repeatedly, replace the unit
111	#	Mains undervoltage	Mains voltage to low Conversion factor diagnostic code → voltage value (AC 230 V: 1,683; AC 120 V: 0,843)
112	0	Mains voltage recovery	Error code for triggering a reset on power restoration (no error)
113	#	Internal error mains voltage supervision	Make a reset; if error occurs repeatedly, replace the unit
115	#	Internal error system counter	
116	0	Designed lifecycle exceeded (250,000 startups)	Warning threshold has been reached. The unit should be replaced
117	0	Life time exceeded Operation no longer allowed	Switch-off threshold has been reached
120	0	Interrupt limitation fuel counter input	Too many disturbance pulses at the fuel meters input → Improve EMC
121	#	Internal error EEPROM access	Make a reset, repeat last parameterization / check. Restore the parameter set, if error occurs repeatedly, replace the unit
122	#	Internal error EEPROM access	Make a reset, repeat last parameterization / check. Restore the parameter set, if error occurs repeatedly, replace the unit
123	#	Internal error EEPROM access	Make a reset, repeat last parameterization / check. Restore the parameter set, if error occurs repeatedly, replace the unit
124	#	Internal error EEPROM access	Make a reset, repeat last parameterization / check. Restore the parameter set, if error occurs repeatedly, replace the unit

Error code	Diagnostic code	Meaning for the LMV37.4... system	Remedy
125	#	Internal error EEPROM read access	Make a reset, repeat last parameterization / check. If error occurs repeatedly, replace the unit
126	#	Internal error EEPROM write access	Make a reset, repeat last parameterization / check. If error occurs repeatedly, replace the unit
127	#	Internal error EEPROM access	Make a reset, repeat last parameterization / check. Restore the parameter set, if error occurs repeatedly, replace the unit
128	0	Internal error EEPROM access - synchronization during initialization	Make a reset; if error occurs repeatedly, replace the unit
129	#	Internal error EEPROM access – command synchronization	Make a reset, repeat last parameterization / check. If error occurs repeatedly, replace the unit
130	#	Internal error EEPROM access - timeout	Make a reset, repeat last parameterization / check. If error occurs repeatedly, replace the unit
131	#	Internal error EEPROM access - page on abort	Make a reset, repeat last parameterization / check. If error occurs repeatedly, replace the unit
132	#	Internal error EEPROM register initialization	Make a reset; if error occurs repeatedly, replace the unit
133	#	Internal error EEPROM access – Request synchronization	Make a reset, repeat last parameterization / check. If error occurs repeatedly, replace the unit
134	#	Internal error EEPROM access – Request synchronization	Make a reset, repeat last parameterization / check. If error occurs repeatedly, replace the unit
135	#	Internal error EEPROM access – Request synchronization	Make a reset, repeat last parameterization / check. If error occurs repeatedly, replace the unit
136	#	Restore	
	1	Restore started	Restore of a backup has been started (no error) New devices require resetting following restore!
		for further diagnostic codes for error code 136, refer to error code 137	For measures, refer to error code 137
137	#	Internal error – backup / restore	
	157 (-99)	Restore – ok, but backup < data set of current system	Restore successful, but backup data set is smaller than in the current system
	239 (-17)	Backup – storage of backup in AZL2... faulty	Make reset and repeat backup
	240 (-16)	Restore – no backup in AZL2..	No backup in AZL2..
	241 (-15)	Restore – interruption concerning unpassable ASN	The Backup has a unpassable ASN and may not restore of the unit
	242 (-14)	Backup – backup made is inconsistent	Backup is faulty and cannot be transferred back
	243 (-13)	Backup – data comparison between µCs faulty	Repeat reset and backup
	244 (-12)	Backup data are incompatible	Backup data are incompatible with the current software version, restore not possible
	245 (-11)	Access error to parameter Restore_Complete	Repeat reset and backup
	246 (-10)	Restore – timeout when storing in EEPROM	Repeat reset and backup

Error code	Diagnostic code	Meaning for the LMV37.4... system	Remedy
	247 (-9)	Data received are inconsistent	Backup data set invalid, restore not possible
	248 (-8)	Restore cannot at present be made	Repeat reset and backup
	249 (-7)	Restore – abortion due to unsuitable burner identification	Backup has an unsuitable burner identification and must not be transferred to the unit
	250 (-6)	Backup – CRC of one page is not correct	Backup data set invalid, restore not possible
	251 (-5)	Backup – burner identification is not defined	Define burner identification and repeat backup
	252 (-4)	After restore, pages still on ABORT	Repeat reset and backup
	253 (-3)	Restore cannot at present be made	Repeat reset and backup
	254 (-2)	Abortion due to transmission error	Repeat reset and backup
	255 (-1)	Abortion due to timeout during restore	Make a reset, check the connections and repeat the backup
146	#	Timeout building automation interface	Refer to User Documentation Modbus (A7541)
	1	Modbus timeout	
150	#	TÜV test	
	1 (-1)	Invalid phase	TÜV test may only be started in phase 60 (operation)
	2 (-2)	TÜV test default output too low	TÜV test default output must be lower than the lower output limit
	3 (-3)	TÜV test default output too high	TÜV test default output must be higher than the upper output limit
	4 (-4)	Manual abortion	No error: Manual abortion of TÜV test by the user
	5 (-5)	TÜV test timeout	No loss of flame after fuel valves have been shut 1. Check for extraneous light 2. Check wiring for short-circuit 3. Check to see if one of the valves is leaking
165	#	Internal error	
166	0	Internal error watchdog reset	
167	#	Manual locking	Unit has been manually locked (no error)
	1	Manual locking by contact	
	2	Manual locking by AZL2...	
	3	Manual locking by PC software	
	8	Manual locking by the AZL2... Timeout / communication breakdown	During a curve adjustment via the AZL2..., the timeout for menu operation has elapsed (setting via parameter 127), or communication between the LMV37.4... and the AZL2... has broken down
	9	Manual locking by the PC software Communication breakdown	During a curve adjustment via the ACS410, communication between the LMV37.4... and the ACS410 was interrupted for more than 30 seconds
	33	Manual locking after PC software reset attempt	PC software made a reset attempt although the system worked correctly
168	#	Internal error management	Make a reset; if error occurs repeatedly, replace the unit
169	#	Internal error management	Make a reset; if error occurs repeatedly, replace the unit
170	#	Internal error management	Make a reset; if error occurs repeatedly, replace the unit
171	#	Internal error management	Make a reset; if error occurs repeatedly, replace the unit

Error code	Diagnostic code	Meaning for the LMV37.4... system	Remedy
200 OFF	#	System error-free	No error
201 OFF UPR	#	Start prevention	Start prevention due to unparameterized unit Go to error history, entry 702, for initial cause of the error with shutdown in connection with the first curve settings
	Bit 0 Valency 1	No operating mode selected	
	Bit 1 Valency 2..3	No fuel train defined	
	Bit 2 Valency 4..7	No curves defined	
	Bit 3 Valency 8..15	Standardized speed undefined	
	Bit 4 Valency 16..31	Backup / restore was not possible	
202	#	Internal error operating mode selection	Redefine the operating mode (parameter 201)
203	#	Internal error	Redefine the operating mode (parameter 201). Make a reset; if error occurs repeatedly, replace the unit
204	Phase number	Program stop	Program stop is active (no error)
205	#	Internal error	Make a reset; if error occurs repeatedly, replace the unit
206	0	Inadmissible combination of units (basic unit - AZL2...)	
207	#	Version compatibility basic unit - AZL2...	
	0	Basic unit version too old	
	1	AZL2... version too old	
208	#	Internal error	Make a reset; if error occurs repeatedly, replace the unit
209	#	Internal error	Make a reset; if error occurs repeatedly, replace the unit
210	0	Selected operating mode is not released for the basic unit	
240	#	Internal error	Make a reset; if error occurs repeatedly, replace the unit
245	#	Internal error	Make a reset; if error occurs repeatedly, replace the unit
250	#	Internal error	Make a reset; if error occurs repeatedly, replace the unit

11. Electric equipment

11.1 Safety system

The safety system (safety switch for hatches, doors, water level, pressure, temperature and other safety devices) must be installed in the safety circuit in accordance with current regulations for the system. This can differ between different systems in which the burner is installed, see rules and regulations that apply.

The cables of the safety system must be separated so that the outgoing signal is not placed in the same cable as the incoming signal.

Manual reset with remote reset (optional)

The remote reset shall be installed with a cable connected from X1: 14 which goes to the remote reset switch and back to X1: 5.

11.2 Wiring diagram

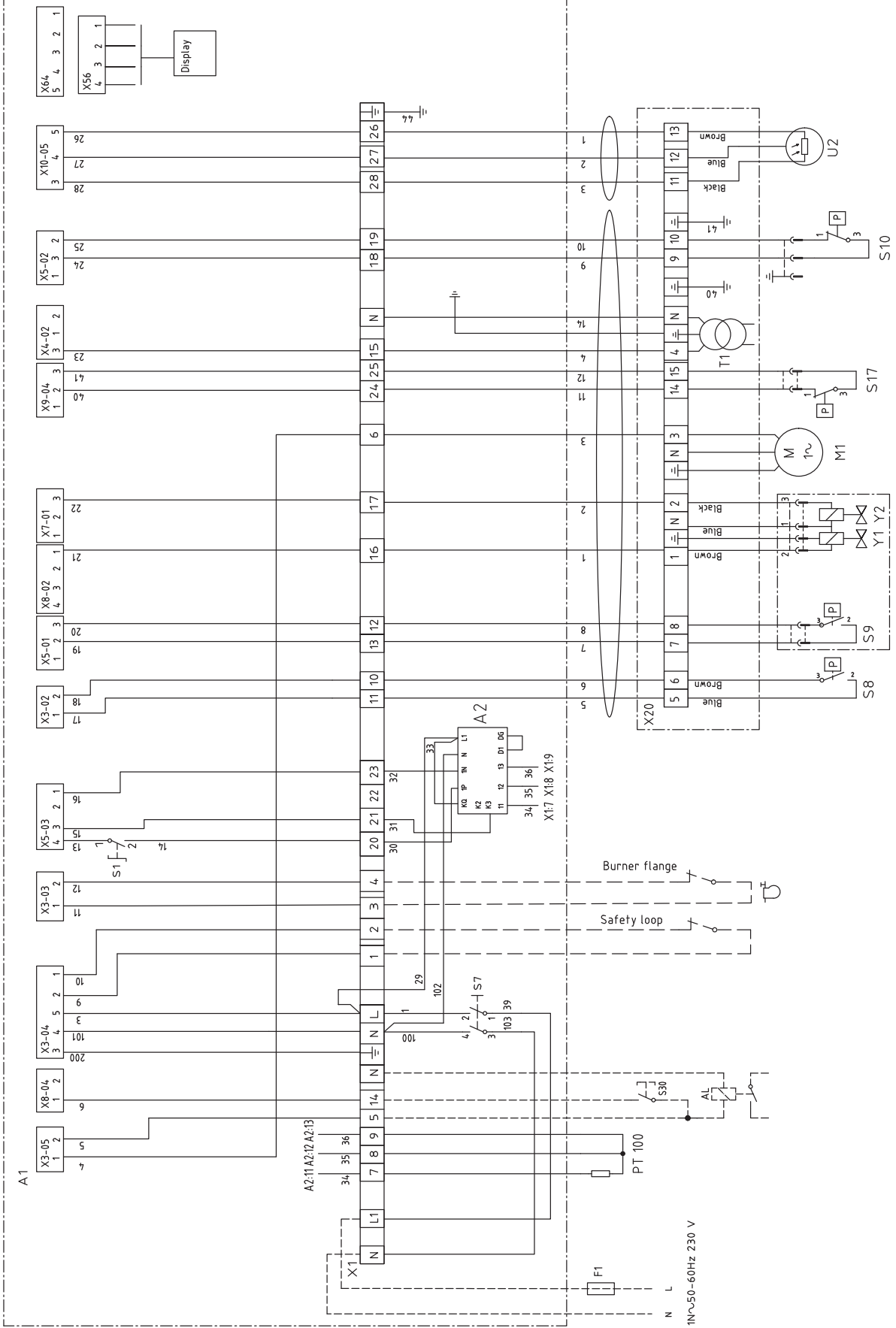

11.2.1 List of components

A1	Burner control LMV37	S1	Operating switch 0-I	T1	Ignition transformer
A2	Regulator RWF50	S7	Main switch	U2	Flame detector QRC
AL	Alarm	S8	Air pressure switch	X1	Connection block
F1	Fuse	S9	Gas pressure switch, min	X20	Connection block
K1	Contactor + motor protection	S10	Gas pressure switch, max	X56	Connection display
M1	Burner motor	S17	Gas pressure switch VPS	Y1	Solenoid valve 1
PT100	Sensor	S30	Extern reset	Y2	Solenoid valve 2

11.2.2 Components, electrical cabinet

- | | | | | | |
|----|------------------|----|---|----|----------------------|
| 1. | Main switch | 4. | Automatic control unit LMV | 6. | Reset |
| 2. | Fuse | 5. | Display AZL
(automatic control unit) | 7. | Operating switch 0-I |
| 3. | Connection block | | | 8. | Regulator RWF |

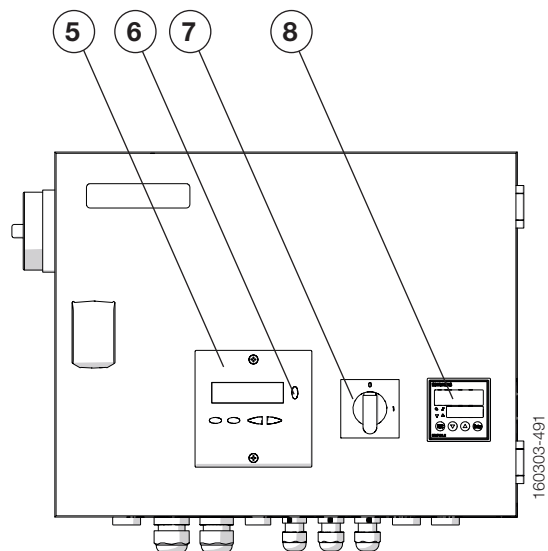
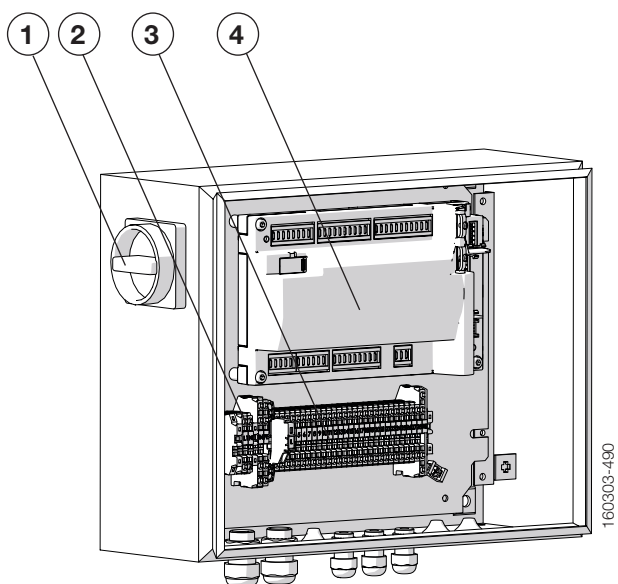

12. Handing over of the installation

- Make repeated start attempts to ensure that the adjustments function.
- Close the ball valve during operation to check that the gas switch switches off at the set value.
- Remove the hose for the air pressure switch to check that the burner locks out.
- Check that all protective covers and measurement nipples are mounted and fastened.
- Fill out necessary test reports.
- Instruct the persons in charge of the operation on the service and maintenance of the installation and what to do should any troubles occur.
- Inspection and service must be carried out by authorized personnel.



Review and service should be performed by authorised personnel only.

13. Troubleshooting

Conditions favourable to trouble-free operation of the system can only be guaranteed through the interaction between three factors: electricity, gas flow and combustion air. If any of these factors change, it may cause a malfunction.

Before requesting servicing, check the following points:

1. Are the system's gas taps open?
2. Are the fuses intact and is the power on?
3. Are control devices (room thermostat, boiler thermostat, etc.) correctly set?
4. Is there sufficient gas pressure to the burner?
5. Are the burner controls on standby and not locked?
6. Is there sufficient air supply to the burner?

Cause of fault	Action
Burner does not start:	
No gas.	Make sure all gas taps are open.
No power.	Check the fuse, thermostat and electrical connections.
Burner motor does not start.	Motor protection has tripped. Motor faulty.
Burner control faulty.	Replace.

Burner motor running, no ignition spark at the end of pre-aeration:	
No power in the terminals.	Check the connector. Replace faulty burner controls.
Ignition electrodes in contact with each other or earth.	Adjust.
Ignition electrode porcelain damaged.	Replace the electrodes.
Poor connection to cable connectors.	Adjust connection.
Ignition cables damaged.	Replace.
Transformer damaged, no power to secondary winding.	Replace the transformer.
Ignition cable and ionisation cable swapped around.	Reconnect.

No flame propagation:	
Gas solenoid valve faulty.	Replace.
Gas solenoid valve does not open despite having power.	Replace solenoid valve terminals, or entire valve.
No power to solenoid valve.	Check the connection.
No electrical connection through air pressure gauge.	Check the air pressure gauge's settings and functions.
Ignition load incorrectly set.	Increase/decrease gas supply Reduce airflow.
Burner control faulty	Replace
Air pressure gauge incorrectly set or faulty	Check the settings and reset, or replace
No acknowledgement signal due to incorrect adjustment or misalignment of the control motor cams.	Check the settings and realign.

Cause of fault	Action
Burner trips after safety time limit despite flame propagation:	
No ionisation current or UV cell incorrectly positioned.	Adjust ionisation electrode and UV cell Check cables and connectors.
Burner control monitor faulty.	Replace burner control.
Voltage lower than 185V.	Contact an electrician.
Ignition electrodes disrupting ionisation current.	Adjust ignition electrodes. Re-polarise the transformer.
Poor earth connection.	Ensure adequate earth connection.
Phase and neutral swapped around.	Check wiring diagram and change accordingly.

Burner trips during pre-aeration:	
Air sensor faulty or incorrectly set.	Increase/decrease air setting. Reduce air volume.
Ignition load incorrectly set.	Increase/decrease gas supply Reduce airflow.
Gas pressure too low.	Increase pressure. If necessary, contact gas supplier.

Pulsations at start-up:	
Ignition electrodes incorrectly set.	Adjust .
Gas pressure too high.	Check and adjust using pressure gauge and pressure control valve.
Flue gas side blocked.	Check the chimney flue.

Burner pulsates during operation:	
Burner incorrectly set.	Adjust.
Burner dirty.	Clean the burner.
Incorrect chimney.	Check and modify dimensions if necessary.

Burner functioning properly but with occasional blockage:	
Ionisation current too low.	Check. Must be at least 6µA, but should ideally lie between 8-20µA.
UV cell incorrectly positioned.	Adjust.
Voltage drop at certain times.	Must not drop below 15% of rated voltage. Contact an electrician if necessary.
Incorrectly set or faulty air sensor.	Check the settings and reset, or replace.
Ignition electrode overload.	Replace.
Burner control ambient temperature too high.	Insulate for heat, Max. 60 °C.
Ignition spark too weak.	Check the transformer.

Poor combustion:	
Poor draught conditions.	Check the chimney.
Flue gas temperature too high.	Boiler overloaded Decrease the gas volume, sweep the chimney if necessary.
CO ₂ content too low.	Choke the air supply. Check the boiler for any leakages. Choke the draught if too high.

Cause of fault	Action
CO content too high:	
Surplus air when using natural gas and liquefied petroleum (propane, butane).	Choke the air supply.
Poor air supply.	Open the air supply. Check flue gas damper.
Holes in gas nozzle clogged.	Clean.
Poor fresh air intake.	Check and increase.
Flame at incorrect angle due to combustion head out of position.	Check the combustion head and readjust.

Condensation build up in boiler and chimney:	
Flue gas temperature too low or gas volume too low.	Raise the flue gas temperature by increasing gas volume Insulate the chimney.

14. Service- and inspection protocol

Installation	Boiler	
Name:	Type:	Efficiency kW:
Address:	Burner	
	Type:	Efficiency kW:
Installed by:	Date:	

Date	Nm ³ gas/h	Governor		CO ₂	CO	Fluegas temp	Ionisation current	Pressure		Efficiency
		Before	After					Fire room	Chimney	
Measurement				%	%	°C	µ A	mbar	mbar	%
Small Flame										
Large Flame										
Measures										

Date	Nm ³ gas/h	Governor		CO ₂	CO	Fluegas temp	Ionisation current	Pressure		Efficiency
		Before	After					Fire room	Chimney	
Measurement				%	%	°C	µ A	mbar	mbar	%
Small Flame										
Large Flame										
Measures										

Date	Nm ³ gas/h	Governor		CO ₂	CO	Fluegas temp	Ionisation current	Pressure		Efficiency
		Before	After					Fire room	Chimney	
Measurement				%	%	°C	µ A	mbar	mbar	%
Small Flame										
Large Flame										
Measures										

EU Declaration of conformity



Bentone Gas Burners

Certificate No.	Type	Certificate No.	Type
CE-0123CT1269	BFG 1	CE-0123CT1326	BG 550
CE-0123CT1270	STG 120	CE-0123CT1337	BG 600
CE-0123CT1281	STG 146	CE-0123CT1348	BG 650
CE-0123CT1292	BG 300	CE-0123CT1359	BG 700
CE-0123CT1304	BG 400	CE-0123CT1360	BG 800
CE-0123CT1315	BG 450	CE-0123CT1371	BG 950

This declaration of conformity is issued under the sole responsibility of the manufacturer. The object of the declaration described above is in conformity with:

Gas Appliance Regulation 2016/426/EU

Machinery Directive 2006/42/EC

EMC 2014/30/EU

Restriction of the use of certain hazardous substances (RoHS) Directive 2011/65/EU

References to the relevant harmonised standards used or references to the other technical specifications in relation to which conformity is declared:

EN 676+A2:2008

Fulfills the requirements of Annex J/K. Automatic forced draught burners for gaseous fuels.

Additional information can be downloaded at:

www.bentone.com

Enertech AB

Box 309

S-341 26 LJUNGBY

Ljungby, January 26th 2021

Helene Richmond

Managing Director

Enertech AB

