

Multiplex 20 kW-12 MW MP Series

Gas, Oil and Dual Fuel Burner

- Exceptional flame stability
- Wide turndown (up to 30:1)
- Low air and gas pressure requirements
- Inner assembly easily removed
- Combustion tunnel options, heat resistant metal, refractory, silicon carbide
- Low, medium and high velocity options
- Excess air/gas ratio options.

OPERATION

The MULTIPLEX burner has been designed to achieve a high degree of stability over a wide turndown range from relatively low service inlet pressures.

The complete operating range of the standard burners at required pressure is given in the information included in this data sheet.

Gas and air flows would be controlled by any conventional system of linked butterfly valves, proportionator/air butterfly or variable flow valves.

For high excess air operation the air valve would normally be left fully open and controlled by the gas valve only, thus providing a relatively constant volume of combustion products in the furnace throughout the operating range.

BASIC BURNER

The burner is supplied less combustion tunnel. It is suitable for mounting directly to the wall of the application, the combustion tunnel being formed by a suitable hole in the furnace wall.

FUEL

Burners can be supplied for all commercial gases, (light) oil, or dual fuel.

COMBUSTION TUNNELS

Multiplex burners are available with a number of combustion tunnel materials and the following is intended only for general guidance. All sizes, in all materials, can be supplied with extended projection.

METAL COMBUSTION TUNNEL

For low temperature application up to 450°C, standard stainless steel material can be used for the combustion tunnel.

For high temperature applications up to 900°C, a high quality heat resistant stainless steel is available.

SILICON CARBIDE TUNNELS

For high temperature applications up to 1300°C, ceramic fibre-lined furnaces and kilns, silicon carbide combustion tunnels are available.

High velocity up to MP10 only, medium velocity up to MP15 only.

REFRACTORY COMBUSTION TUNNEL

For high temperature applications up to 1450°C, conventional refractory quarts, together with holders are available. These quarts can be cased in heat-resisting stainless steel if required. Ceramic fibre quarts for low and medium velocity can also be supplied.

NOMINAL RATINGS

See the following chart for nominal ratings of burners operating at 10 mbar gas and air pressure at the burner inlet. This assumes balanced chamber conditions.

	MP2	MP4	MP6	MP10	MP15	MP25	MP40	MP60	MP100	MP150	MP250	MP400
kW	60	120	175	295	440	730	1170	1750	2950	4400	7300	11700
Therms/h	2	4	6	10	15	25	40	60	100	150	250	400
Kcal 1000/h	50	100	150	250	375	625	1000	1500	2500	3750	6250	10000

Gas and air pressure for nominal rating are 10 mbar, with additional gas and air pressures, over-firing rates of up to 150% can be achieved. Refer to Nu-way for advice.

MP LEADING DIMENSIONS

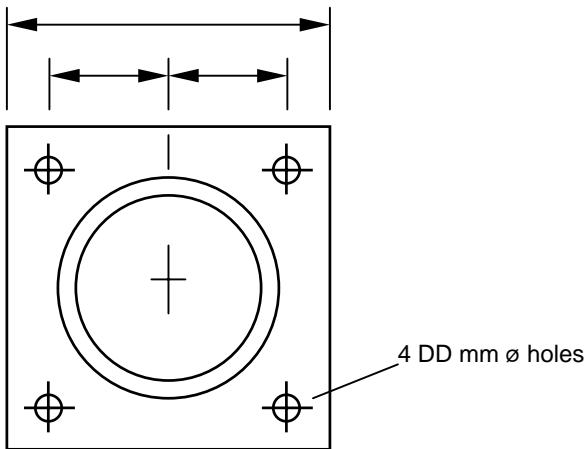

BASIC BURNER MP2 - MP400

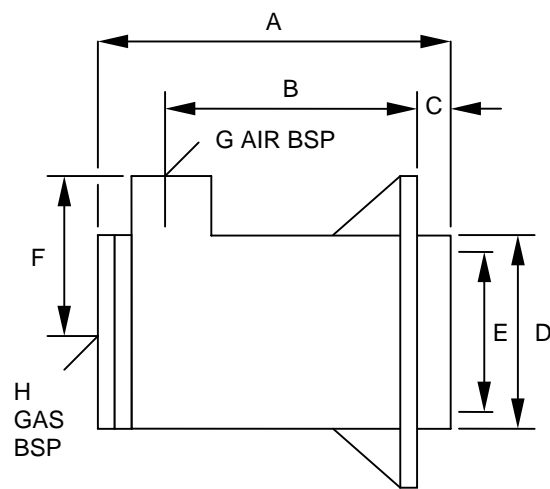

ALTERNATIVE AIR INLETS (TABLE 'D' FLANGE)

MP25 to MP40

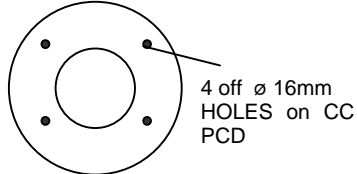

MP60 to 250

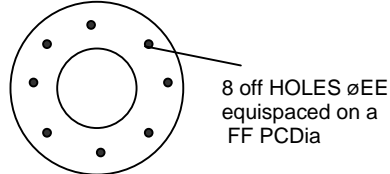

MP400

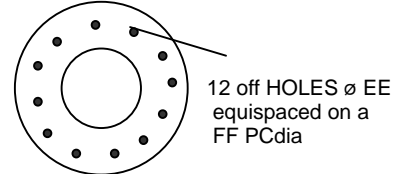

	A	B	C	D	E	F	G	H	J	K	AA	BB	CC	DD	EE dia	FF pcd
MP2	152	73	0	72	50	55	1½"	¾"	102	40	-	-	-	12	-	-
MP4	174	60	45	86	73	65	2"	¾"	130	49	-	-	-	12	-	-
MP6	192	73	45	102	83	70	2"	1"	140	54	-	-	-	12.7	-	-
MP10	275	143	45	133	108	94	2½"	1¼"	187	78	-	-	-	12.7	-	-
MP15	307	165	40	160	135	100	3"	1½"	200	80	-	-	-	13	-	-
MP25	343	200	51	185	161	124	-	2"	248	98	184	90	146	16	-	-
MP40	374	211	51	235	211	147	-	3"	294	121	216	114	178	16	-	-
MP60	561	315	50	297	265	210	-	1½"	440	395	279	165	235	22	22	395
MP100	696	415	50	357	325	250	-	3"	475	425	336	214	292	18	18	425
MP150	965	535	50	456	425	300	-	3"	650	550	406	267	353	22	22	550
MP250	1065	647	65	592	549	400	-	3"	850	725	527	344	470	34	34	725
MP400	1132	699	60	750	695	490	-	3"	1020	900	576	396	520	45	45	1130

COMBUSTION TUNNELS

Metal (MP4 – 400)

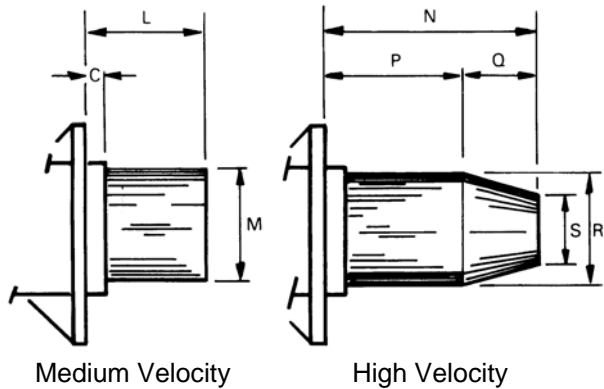

For all MULTIPLEX burners with stainless steel combustion tunnels dimensions given are for standard tunnel length. Tunnels may be extended to suit application requirements. Refractory tunnels can be extended to order.

Refractory (MP2 – 400)

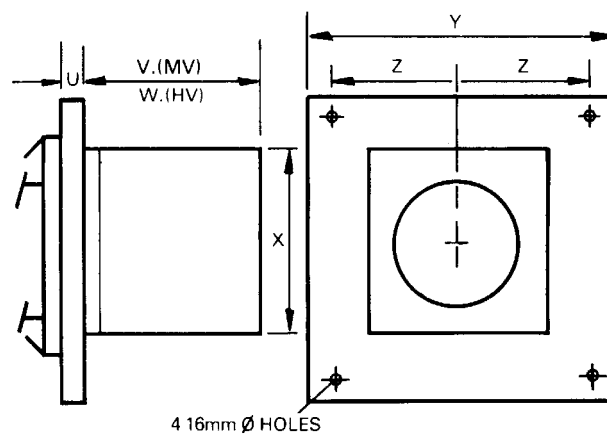

	L	M	N	P	Q	R	S
MP2	80	60	175	80	95	60	33
MP4	187	73	260	180	80	70	40
MP6	200	90	350	200	150	90	45
MP10	217	114	350	217	133	114	58
MP15	265	141	405	265	140	141	72
MP25	290	169*	430	290	140	169	88
MP40	355	219	550	355	195	219	112
MP60	338	269	-	-	-	269	-
MP100	373	329	-	-	-	329	-
MP150	380	429	-	-	-	431	-
MP250	550	550	-	-	-	-	-
MP400	-	-	-	-	-	-	-

	U	V	W	X	Y	Z
MP2	22	110	250	228	305	127
MP4	10	228	338	228	305	127
MP6	10	228	338	228	305	127
MP10	10	228	338	228	305	127
MP15	10	300	439	300	385	164
MP25	10	345	540	347	450	196
MP40	10	325	540	347	450	200
MP60	12.5	325	-	400	500	225
MP100	12.5	367	-	480	600	275
MP150	20	360	-	580	800	720
MP250	20	530	-	750	1060	960
MP400	20	800	-	900	1230	1130

SILICON CARBIDE TUNNELS

For high temperature, ceramic fibre-lined furnaces and kilns, silicon carbide combustion tunnels are available.

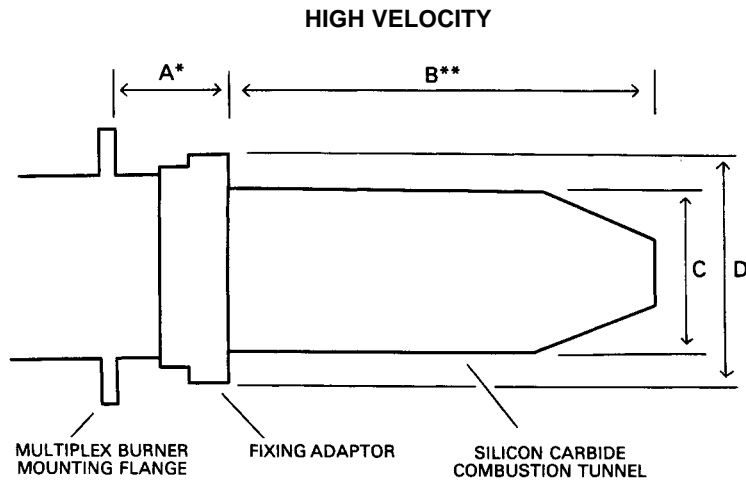

* This dimension can be increased if required

** If $B + A$ or $E + A$ is greater than wall thickness, then stand-off adaptors are available as optional extras

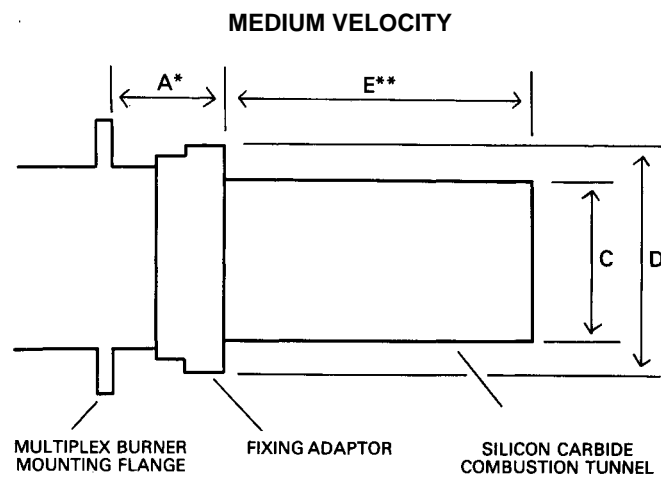

MOUNTING DETAILS

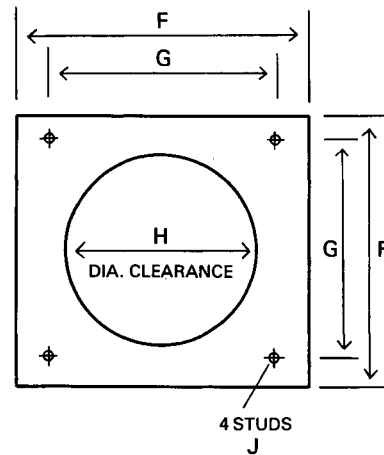

	A	B	C	D	E	F	G	H	J
MP2	46	179	65	85	84	102	81	88	M10 x 40 long
MP4	88	273	80	108	129	130	98	111	M10 x 40 long
MP6	95	308	95	124	160	140	108	128	M10 x 40 long
MP10	93	311	120	150	163	187	156	153	M10 x 40 long
MP15	88	-	146	178	244	200	160	181	M10 x 40 long