

MGN 860 / 1350-LN GAS BURNER

225 - 1350 kW

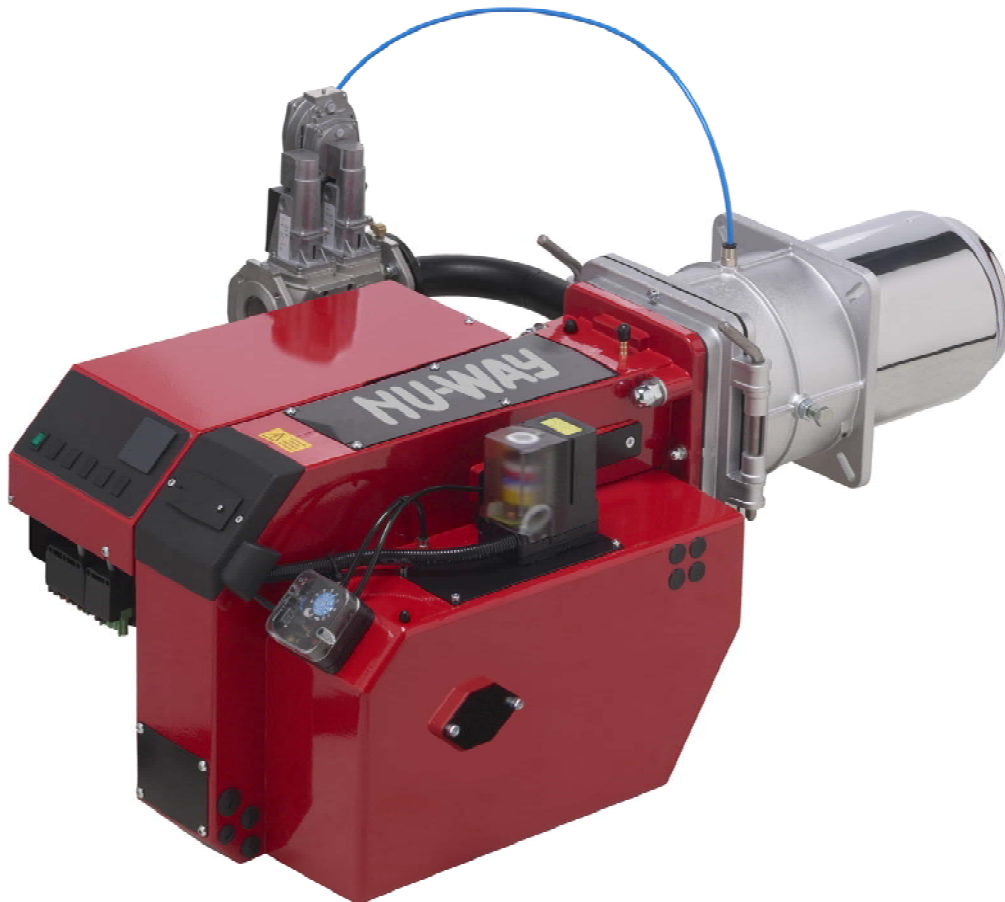

- Energy saving and compatible with environmental requirements
- Quiet in operation and designed for easy maintenance
- Designed and approved in accordance with the European Standard EN 676
- Plug-in contact facilitates the installation
- Hinged flange
- Designed for two-stage or modulating operation
- Available for natural gas, LPG, town gas, biogas
- Low NOx as standard <80 mg/kWh
- All kW ratings are in nett CV

NU-WAY

Type		MGN 860-LN	MGN 1350-LN
Capacity	kW	225-860	225-1350
Motor	V/Hz kW/A	400 / 50 1.1 / 3.6	400 / 50 2.2 / 4.6
Control box		DMG 972 / MPA 22	DMG 972 / MPA 22
Flame monitoring		Ionisation / IRD 1020	
Operation mode		2 stage or modulating	
Gross weight	kg	45	48
Noise emission	dBA	≤ 78	

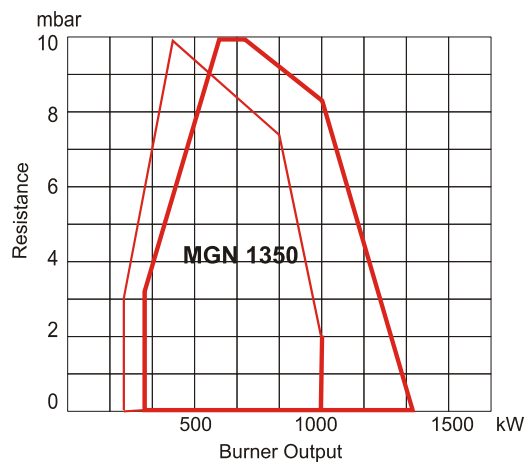
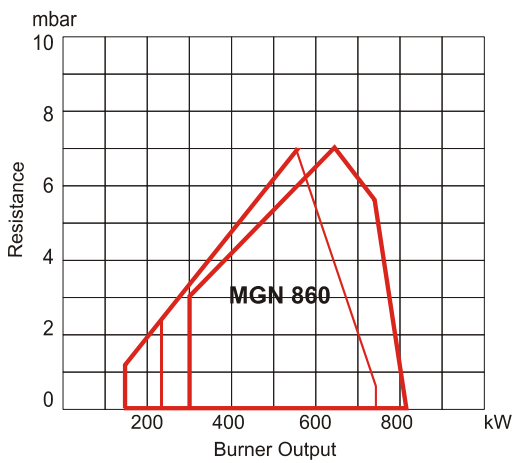

— Burner head "closed" - - - Burner head "open"

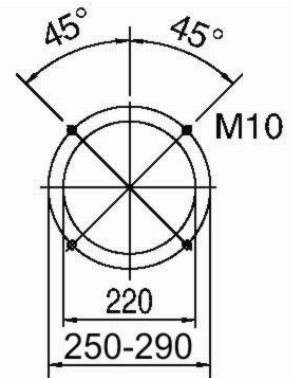
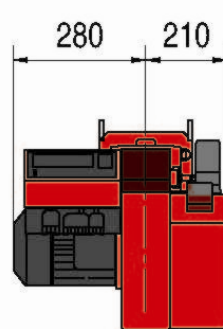
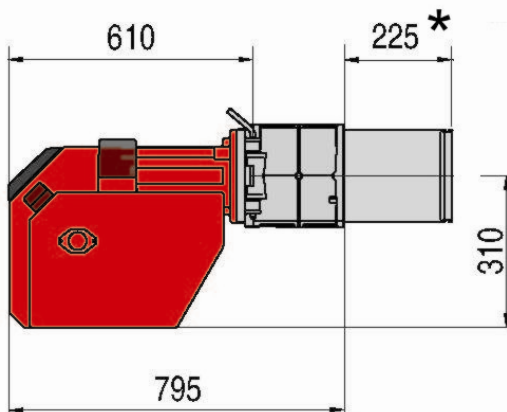

* Extended lengths Available

NU-WAY

Nu-way Limited
P O Box 1, Vines Lane
Droitwich
Worcestershire
WR9 8NA

tel: +44 (0) 1905 794331
fax: +44 (0) 1905 794017

email: info@nu-way.co.uk
web: www.nu-way.co.uk